

# LB1-UW06x-x Cabinet Loudspeakers



## Security Systems

- Good speech intelligibility and background music reproduction
- Finished in white or black
- MDF construction
- Available with or without integral volume control
- Complies with international installation and safety regulations



The 6 W cabinet loudspeakers are intended for good speech intelligibility and background music reproduction in general purpose indoor applications like restaurants, shops, offices and schools.

### Functions

The robust, solid MDF (Medium Density Fiber board) enclosures are covered with a durable, easy-to-clean vinyl in a choice of white or black.

The ABS fronts are covered with fine woven cloth in matching color. The angled front baffle results in a better, improved high frequency reproduction in the listening area.

They are available with or without an integral volume control.

### Parts Included

Quantity	Component
1	cabinet loudspeaker

### Certifications and Approvals

All Bosch loudspeakers are designed to withstand operating at their rated power for 100 hours in accordance with IEC 268-5 Power Handling Capacity (PHC) standards. Bosch has also developed the Simulated Acoustical Feedback Exposure (SAFE) test to demonstrate that they can withstand two times their rated power for short durations. This ensures extra reliability under extreme conditions, leading to higher customer satisfaction, longer operating life, and much less chance of failure or performance deterioration.

Safety acc. to EN 60065

### Installation/Configuration Notes

Three keyholes in the rear panel are provided for easy and quick wall mounting.

A convenient easy-to-use, 4-pole push-in terminal block is present on the rear panel for on-site wiring. This terminal block has provision for power tapping on the 100 V matching transformer in the cabinet. It allows selection of nominal full-power, half-power or quarter-power radiation (i.e. in 3 dB steps)

# BOSCH

## 2 | LB1-UW06-x Uni-Directional Cabinet Loudspeakers

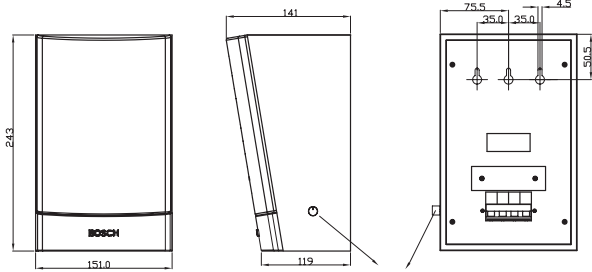

Dimensions LB1-UW06-x, LB1-UW06V-x in mm

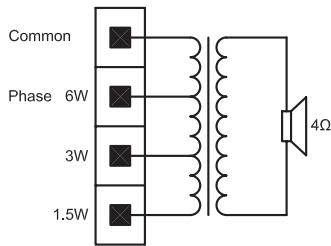

Circuit diagram LB1-UW06-x

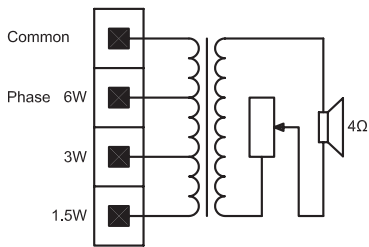

Circuit diagram LB1-UW06V-x

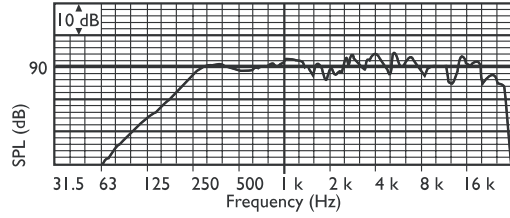

Frequency response

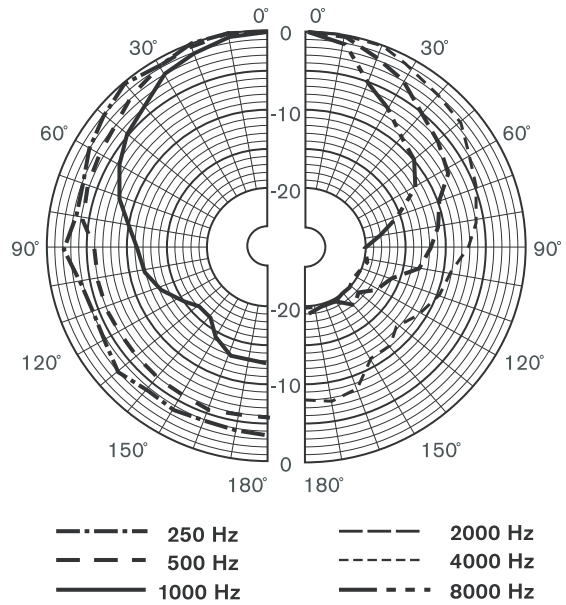

Polar diagram horizontal (measured with pink noise)

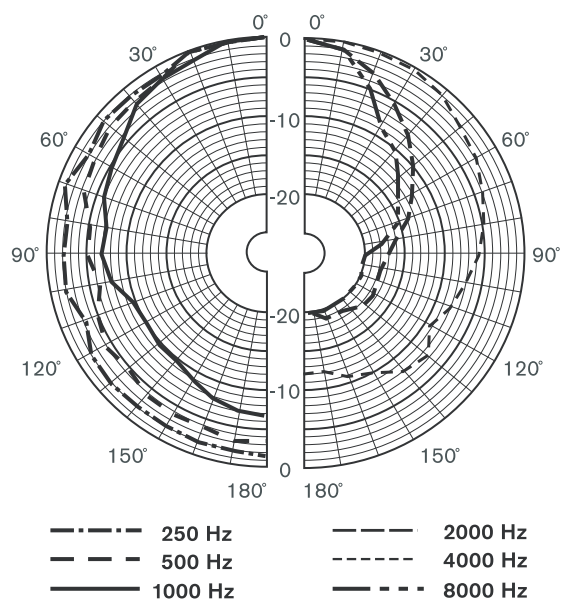

Polar diagram vertical (measured with pink noise)

**Technical Specifications**

Electrical*	
Maximum Power	9 W
Rated Power	6 W (6-3-1.5 W)
Sound Pressure Level at rated Power / 1 W	
(at 1 kHz, 1 m)	99 / 91 dB (SPL)
Effective Frequency Range	180 Hz to 20 kHz (-10 dB)
Opening Angle	
(at 1 kHz / 4 kHz, - 6 dB)	165° / 95°
Rated Input Voltage	100 V
Rated Impedance	1667 ohm

**Mechanical**

Connection	4-pole push-in terminal block
Dimensions	243 x 151 x 141/119 mm
(H x W x D)	(9.5 x 5.9 x 5.6/4.7 inch)
Color	Black (D) or white (L)
Cabinet / Front	Matches RAL 9004 / RAL 9004 (D)
Cabinet / Front	Matches RAL 9010 / RAL 7044 (L)
Weight	0.9 kg

**Environmental**

Ambient Temperature	- 15° to + 55° C
---------------------	------------------

\*) Technical performance data acc. to IEC 60268-5

**Ordering Information****Model & Description**

LB1-UW06-D Cabinet Loudspeaker

6 W, black.

LB1-UW06V-D Cabinet Loudspeaker with Volume Control

6 W, black.

LB1-UW06-L Cabinet Loudspeaker

6 W, white.

LB1-UW06V-L Cabinet Loudspeaker with Volume Control

6 W, white.

**Americas:**

Bosch Security Systems  
130 Perinton Parkway  
Fairport, New York, 14450, USA  
Phone: +1 585 223 4060  
+1 800 289 0096  
security.sales@us.bosch.com  
<http://www.boschsecurity.us>

**Europe, Middle East, Africa:**

Bosch Security Systems B.V.  
P.O. Box 80002  
5600 JB Eindhoven, The Netherlands  
Phone: +31 (0) 40 27 83955  
Fax: +31 (0) 40 27 86668  
emea.securitysystems@bosch.com  
<http://www.boschsecurity.com>

**Asia-Pacific:**

Bosch Security Systems Pte Ltd  
38C Jalan Pemimpin  
Singapore 577180  
Phone: +65 6319 3450  
Fax: +65 6319 3499  
apr.securitysystems@bosch.com  
<http://www.boschsecurity.com>

**BOSCH**