

# 4.6.8.12.16 CHANNEL MIXER

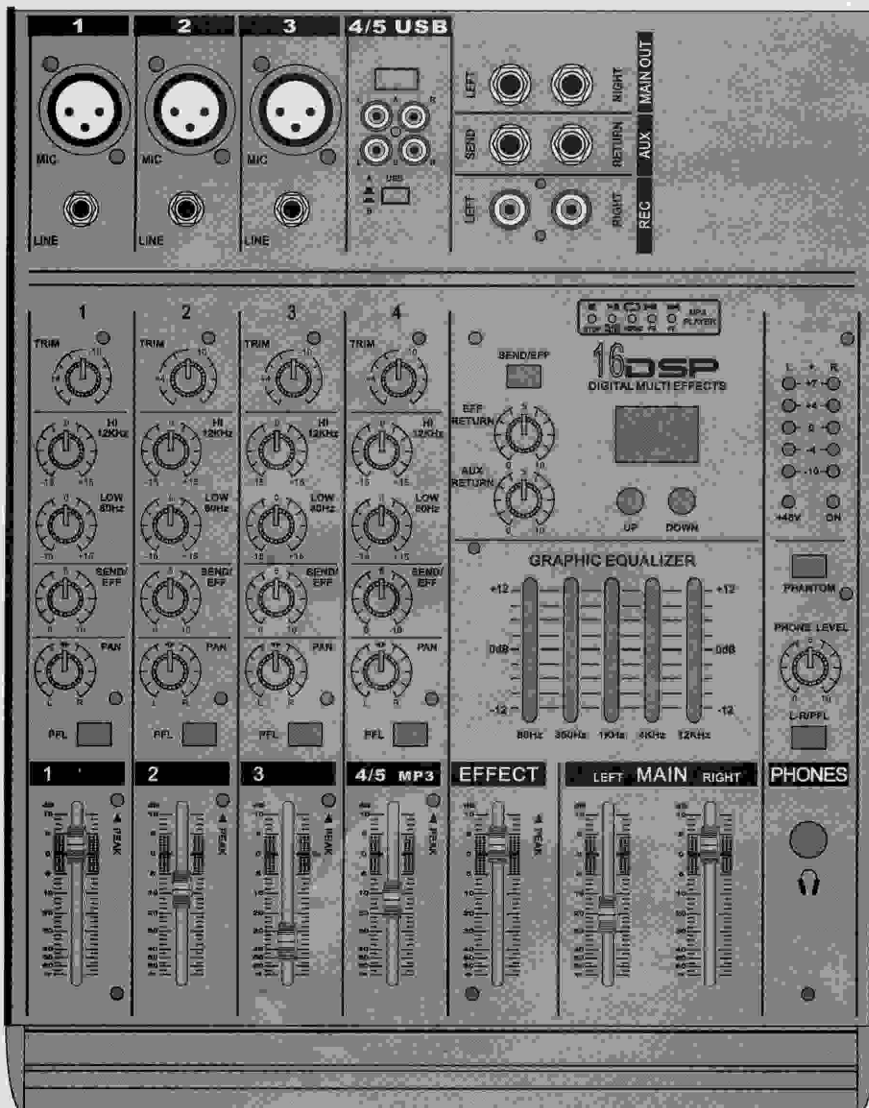

A. INPUT CHANNEL SECTION	2
B. MASTER SECTION	3~4
C. MIXER OUTPUT SECTION	5
D. POWER SECTION	6
E. INSTALLATION	6
F. APPENDIX	7
G. BLOCK DIAGRAM	8

# Ultra low noise 4 Channel Mic / Line Mixer

- ▲ 4 Mono Input Channels with gold plated XLRs and balanced Line Inputs
- ▲ Ultra-low noise discrete Mic Preamps with +48 V Phantom Power
- ▲ Extremely high headroom –offering more dynamic range
- ▲ Balanced Inputs for highest signal integrity
- ▲ Ultra-musical 2-band EQ on all channels
- ▲ Peak LEDs all Mono Channels
- ▲ 1 Aux Send per channel for external effects and monitoring
- ▲ Build in digital multi (16 DSP)
- ▲ Master Mix Output and rec output
- ▲ Highly accurate 10 segment Bargraph Meters
- ▲ Separate Master Mix Outputs

## SAFETY INSTRUCTIONS

**CAUTION:** To reduce the risk of electrical shock, do not remove the cover (or back). No user serviceable parts inside; refer to servicing to qualified personnel.



**WARNING:** To reduce the risk of fire or electrical shock, do not expose this appliance to rain or moisture.



This symbol, wherever it appears, alerts you to the presence of uninsulated dangerous voltage inside the enclosure voltage that may be sufficient to constitute a risk of shock.



This symbol, wherever it appears, alerts you to important operating and maintenance instructions in the accompanying literature. Read the manual.

# A. INPUT CHANNEL SECTION

## 1. Circuitry A、 B&USB input

## 2. Circuitry A、 B or USB input select

## 3. TRIM

This has a function which adjusts the input sensitivity of each channel in order to input the constant level of the signal.

## 4. HI EQ

This control gives you up to 15 dB of boost or cut at 12KHz and above, and it is also flat at the detent. Use it to add sizzle to cymbals, and an overall sense of transparency or edge to key- boards, vocals, guitar, and bacon frying. Turn it down a little to reduce sibilance, or to hide tape hiss.

## 5. LOW EQ

This control gives you up to 15 dB boost or cut at 80Hz and below. This circuit is flat (no boost or cut) at the center detent position. This frequency represents the punch in bass drums, bass guitar, fat synth patches, and some really serious male singers.

## 6. SEND /EFF

This is normally derived after the EQ and channel fader (POST FADE, POST EQ), and is therefore follow any changers in fader level. They are normally used to drive effects processing units which are fed back into the mixer and which must fade out with the input channel.

## 7. PAN

The pan control sends continuously variable amounts of the post fader signal to either the left and right main busses. In the center position equal amounts of signal are sent to the left and right.

## 8. CHANNEL FADER

This is function to adjust the volume of signal connection into each channel and adjust the volume of output, together with master fader. Normal operating position is at the " 0 " mark, providing 4dB of gain above that point, if required.

## 9. PEAK

A red LED indicates a signal level at the insert return point, premaster fader, it illuminates at approximately 5 dB below clipping.

## 10.USB

HOST(USB2.0) Function (MAX 500 MA)  
used for U disk, MP3, hard Disc & flash disc reader, etc.

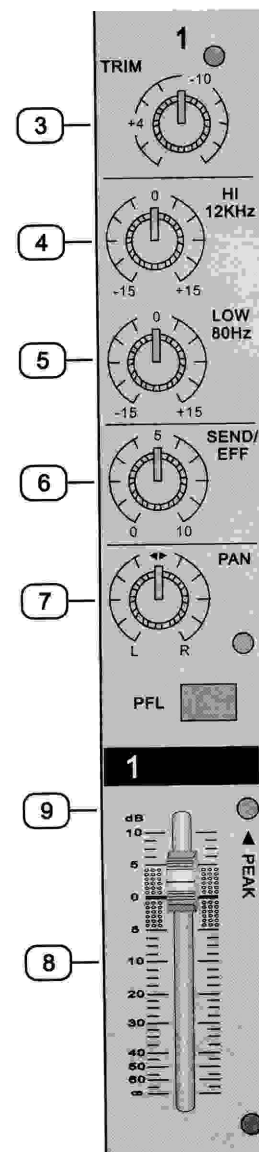
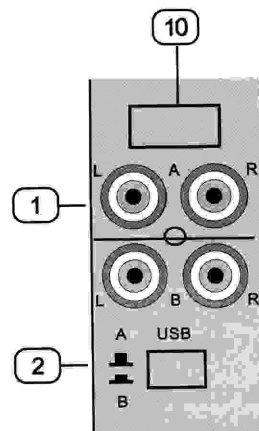

## B. MASTER SECTION

### 11. SEND / EFFECT

When this button is up, Post signal work as send signal.

When this button is down, post signal work as EFFECT signal.

### 12. EFFECT RETURN

This is used for adjusting frequency of echo repeat; since too echo repeat may cause a howl, please adjust frequency properly.

### 13. AUX RETURN

This is used for adjusting frequency of echo repeat; since too echo repeat may cause a howl, please adjust frequency properly.

### 14. EFFECT PROGRAMS

When adjust switch 19,20,21,22 , ore effects are displayed.

### 15. UP TAPE SWITCH

One push, one program up, push with more than 5 swconds.

### 16. DOWN TAPE SWITCH

One push, one program down, push with more than 5 swconds, hi-speed program down.

### 17. EFFECT LEVEL

Using by this control, you can adjust signal level of echo repeat & exteral effect.

### 18. STEREO GRAPHIC EQUALIZER

2X5-band equalizer is provided for tone control over each frequency, and for precise high quality sound by final tone control.

### 19. OUTPUT MAIN FADER (LEFT/RIGHT)

This is a master fader for adjustment for volume of left/right output. Unity gain is the top their travel.

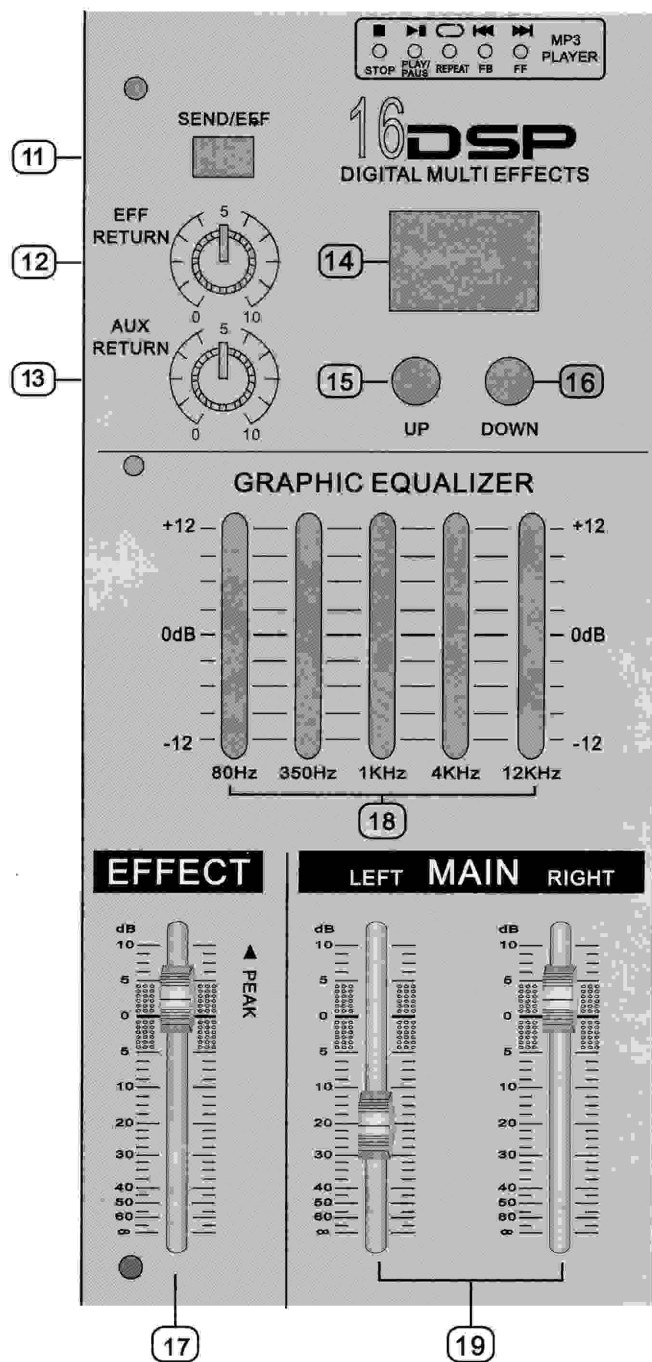

## 20. POWER LED

The POWER LED will be turned on when start working.

## 21. PHANTOM LED

The LED will be turned on 48V DC when start working.

## 22. PHANTOM POWER SWITCH

Depressing this switch applies 48V DC across all microphone input channels connectors for remote powering of condenser microphones.

## 23. HEADPHONE LEVEL

This is a single volume control sends the level to the headphones and main monitors.

## 24. HEADPHONE SWITCH

When L-R/PFL switch up, could monitor stereo (L-R) output signal when L-R / PFL switch down, could monitor group (PFL) output signal.

## 25. HEADPHONE JACK

You can monitor working condition by sound through the headphone.

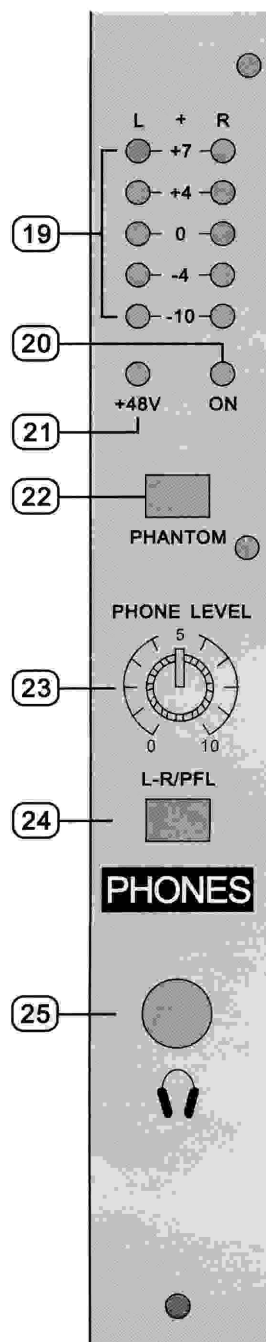

## C. MIXER OUTPUT SECTION

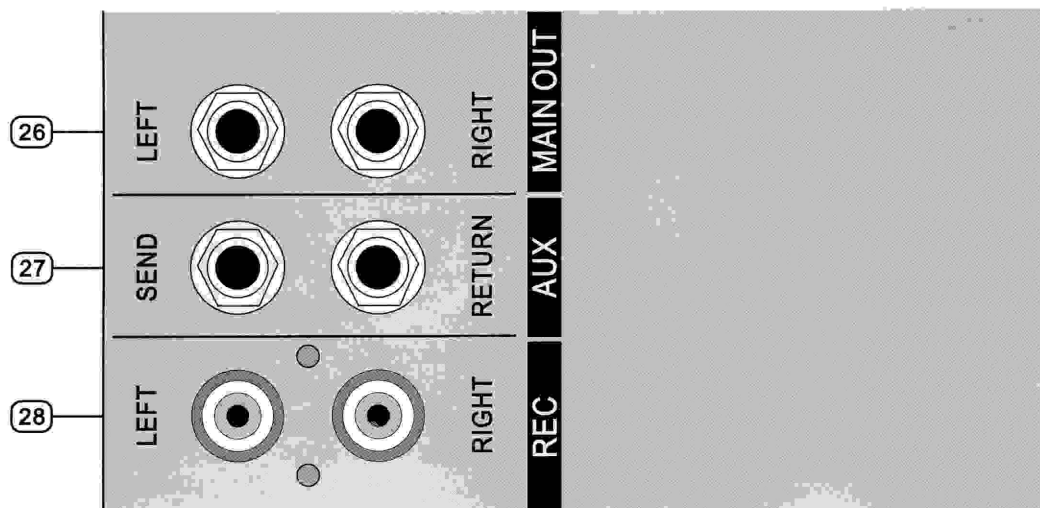

### 26. MAIN OUTPUT JACK (LEFT / RIGHT)

In this product, the final confirmed sound can be sent to main amplifier through jack.

### 27. AUX SEND/RETURN JACK

This can be used to connect all kinds of effect form outside.

### 28. RECORD PIN JACK

This jack is to be connected with cassette deck when recording the mixed output.

# D. POWER SECTION

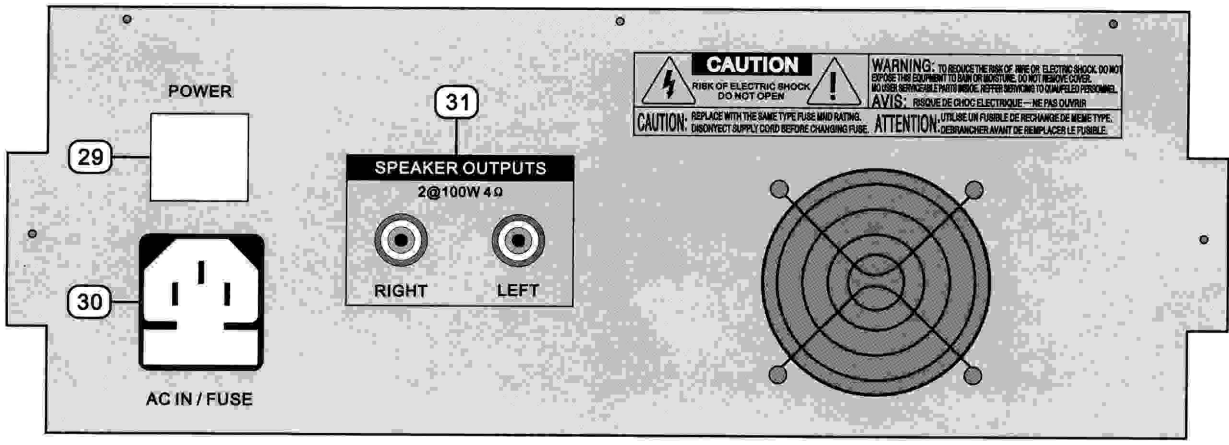

## 29. POWER SWITCH

Push marked (1), when you want to operate. The LED (SEE NO, 33) will be turned on when working

## 30. POWER JACK

This is out of connect the power supply (2 X AC 120V or 230V )jack.

## 31. SPEAKER JACK

This is same functions as below but the using jack different.

# E. INSTALLATION

Experience tells us that the cables in a studio environment get tangled very quickly (inviting mistakes).

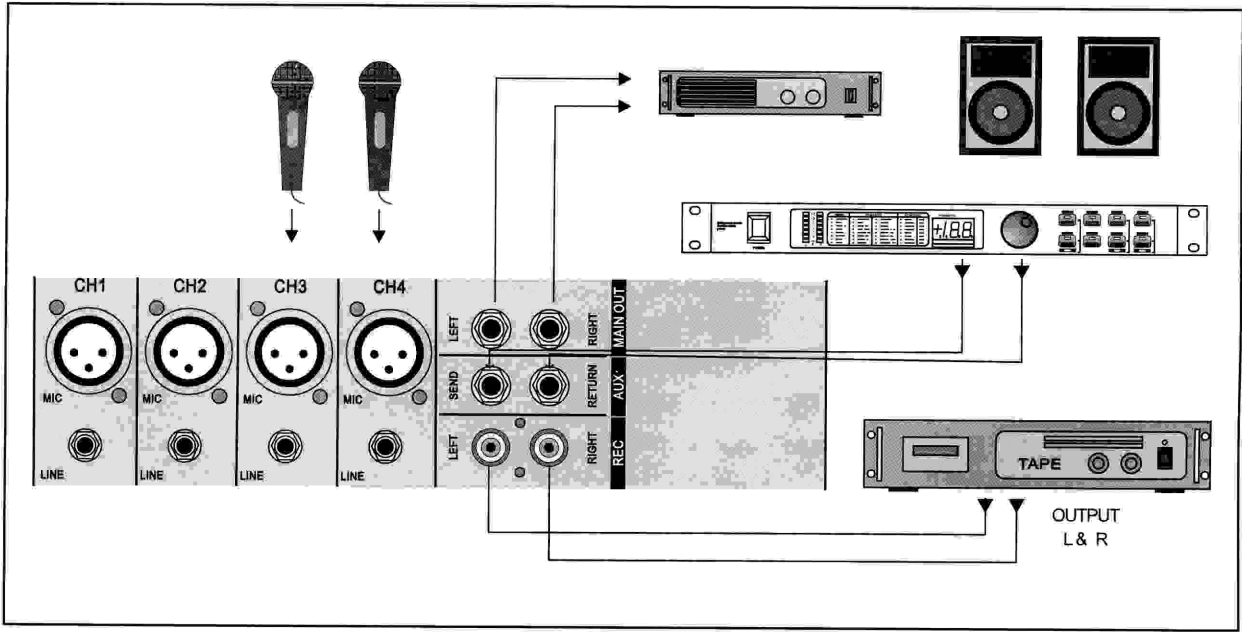



# F. APPENDIX

## Specifications

### Mono Inputs

Mic Input	electronically balanced, discrete input configuration
Bandwidth	10 Hz to 60 kHz $\pm$ 3 dB
Distortion (THD & N)	0.01% at + 4 dBu, 1 kHz, Bandwidth 80 kHz
Mic E.I.N (22 Hz - 22 kHz)	-129.5 dBu, 150 Ohm source -117.3 dBqp, 150 Ohm source -132.0 dBu, input shorted -122.0 dBqp, input shorted +10dB to +60dB

### TRIM range

Line Input	electronically balanced
Bandwidth	10Hz to 60 kHz $\pm$ 3 dB
Distortion (THD & N)	0.01% at + 4 dBu, 1 KHz, Bandwidth 80 kHz
Line level range	+10dBu to -40 dBu
Equalization	
Hi Shelving	12kHz +/-15 dB
Lo Shelving	80Hz +/-15dB

### Master Mix section

Max Output	+22 dBu balanced
Aux Send Max Out	+22 dBu unbalanced
Control Room Out	+22 dBu unbalanced
Signal-To-Noise Ratio	112 dB, all channels at Unity Gain

### Power supply

Mains voltages	USA/Canada ~ 120 V AC, 60 Hz
	U.K./Australia ~240 V AC, 50 Hz
	China ~220 V AC, 50 Hz

<b>Power</b>	2 $\times$ 100W(4 $\Omega$ )
--------------	------------------------------

# C. BLOCK DIAGRAM

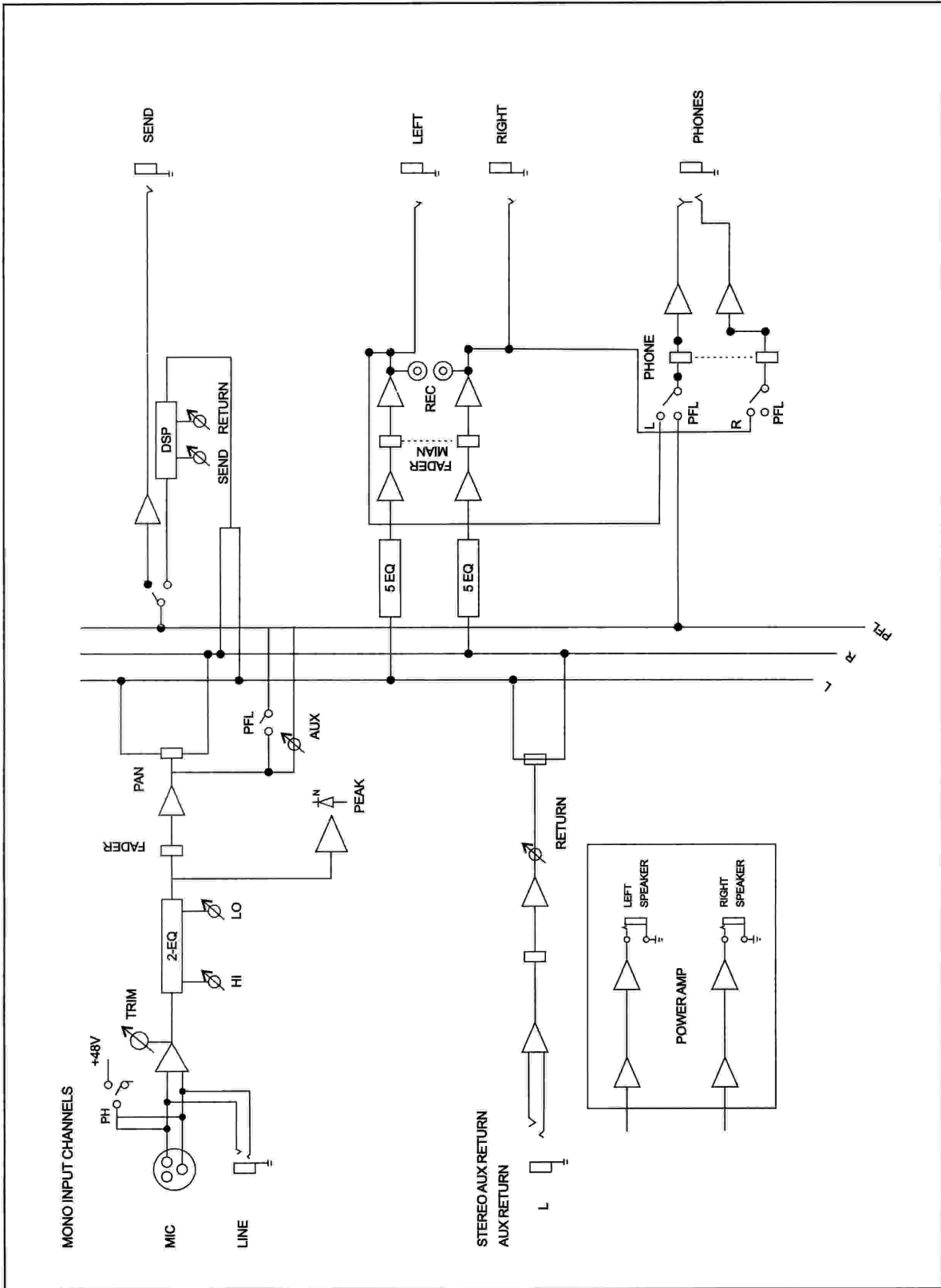

**This device complies with Part 15 of the FCC Rules.**  
**Operation is subject of the following two**  
**conditions : (1) this device may not cause harmful**  
**interference, and (2) this device must accept any**  
**interference receiver, including interference that**  
**may cause undesired operation.**