

SAFETY PRECAUTIONS!

WARNING - TO REDUCE THE RISK OF FIRE OR ELECTRIC SHOCK, DO NOT EXPOSE THIS UNIT TO RAIN OR MOISTURE.

Do not allow water or liquids to be spilled into this unit. If the unit has been exposed to rain or liquids, please unplug the power cord immediately from the outlet (with DRY HANDS) and get a qualified service technician to check it. Keep this unit away from heat sources such as radiators, heat registers, stoves, etc.

This unit contains no user-serviceable parts. Refer all service needs to a qualified service engineer through a Globe dealer.



This triangle on your component alerts you to the presence of uninsulated dangerous voltage inside the enclosure that may be sufficient to constitute a risk of shock.

This triangle on your component alerts you to important operating and maintenance instructions in this accompanying literature.

CAUTION:

TO REDUCE THE RISK OF ELECTRIC SHOCK, DO NOT REMOVE COVERS (OR BACK). NO USER-SERVICEABLE PARTS ARE INSIDE. REFER ALL SERVICING TO A QUALIFIED SERVICE PERSONNEL.

Keep this unit clean by using a soft dry brush and occasionally wiping it with a damp cloth. Do not use any other solvents, which may damage the paint or plastic parts. Regular care and inspection will be rewarded by a long life and maximum reliability.

Your **CS series Mixer** Was Carefully packed at the manufacturing site and the packing box was designed to protect the unit from rough handling. We recommend that you carefully examine the packaging and its contents for any signs of physical damage, which may have occurred during transportation.

If the unit is damaged: ***Notify your dealer and the shipping company immediately.*** Claims for damage or replacement may not be granted if not reported properly or in a timely manner.

GETTING STARTED

INTRODUCTION

Congratulations on your purchase of CS series mixer. Although it has compact construction, and looks cabinet, they are perfect in functions. It is ideal for small live gigs, recording and fixed PA installations. In order to get the best performance from the mixer, please read this user's manual carefully. Please familiarize yourself with the new and different functions on this mixer.

FEATURES

- Low noise 12/16/20 channel Mic/Line-mixer
- 4/8/12 mono inputs with XLR-sockets, +48V Phantom-power and balanced line inputs
- 4 stereo inputs with balanced 1/4" jack sockets
- Stereo inputs can also be operated mono
- 3-band EQ with semi-parametric mids for all mono inputs
- 4-band EQ for all stereo inputs
- Peak-LED and switchable Low Cut per mono input
- 2 Aux-Send (pre/post) per channel for controlling external effectors and for monitoring
- 2 stereo Aux-Return with balanced 1/4" jack sockets
- Built in DSP effect processor with 16 kinds of effects
- Built in USB audio interface can be easily connected to some audio equipments with optical, coaxial input/outputs controlled by USB of a computer(only for CS-U series)
- Separate Main Mix, Control Room and headphones outputs
- Stereo "TAPE IN" for recorder playback or CD playback or linking to sub-mixer
- Record output
- Precise 2x11 LED meter with peak hold
- 60-mm high-quality faders

1. Check the AC voltage before connecting the AC plug. Proper grounding is a necessary practice to prevent electric shock hazards to the operator, the microphone user, and the musicians who are wired to this unit.
2. Before switching on the main power, keep all the output fader all the way down to prevent damage or excessive noise caused by bad level adjustment, wrong wiring, defective cables or bad connection.
3. Always turn on the mixer before the power amplifier; turn off the mixer after the amplifier.
4. Always turn off the unit before connecting and disconnecting the unit from the power source.
5. Never use solvents to clean the unit. Clean with a soft, dry cloth.

Specially the CS-U series of mixer has equipped an inner USB audio interface, by this part the mixer has a 16bit/48KHz A/D & D/A conversion function and an USB data communication function with a computer. This has made data exchange from this mixer to a computer easily and quickly, but also got better quality for recording and playing. One hand, the main out signals of the mixer can be exchanged to PCM digital signals via this interface, then send to computer by USB port to be recorded, edited, saved and exchanged format; on the other hand, all kinds of audio files such as wav, mp3 and midi can be exchanged to normal audio signals via this interface, then be fed to the main bus of the mixer for playing. Otherwise the computer can receive PCM audio signals from other source with optical or coaxial out by this interface, send digital audio files to a active sound box with coaxial in by this interface.

CONTENTS

Safety precautions	2
Introduction / features	3
Channel strip description	
Mono channel section	4
The stereo channel	6
Master section description	7
Main out and other linker	8
Specifications	9

MONO CHANNEL SECTION

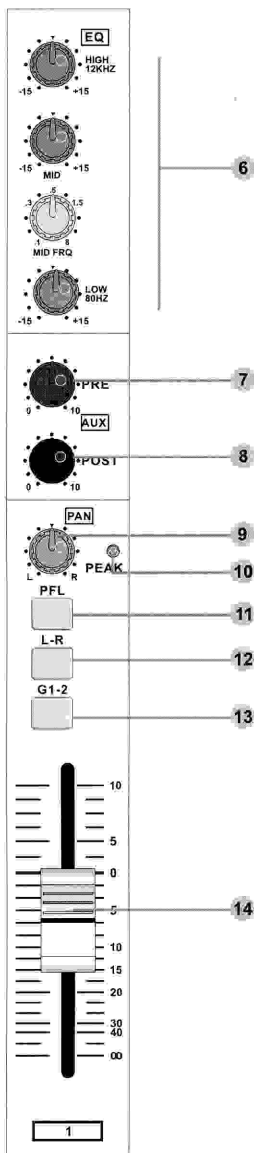
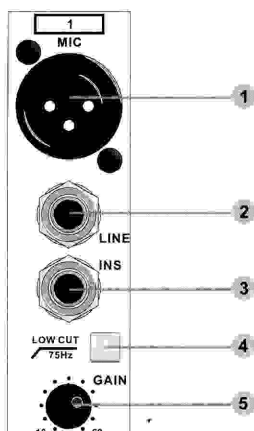

1 MIC

Here, you can connect condenser microphones or dynamic microphones via balanced XLR-cables. For condenser microphones, you can activate the phantom power via the relevant +48V-switch. Please respect the warnings under +48V-switch.

2 LINE

Here, you can connect line-signals via balanced or unbalanced jack plugs. Please not: Never activate the phantom-power when connection unbalanced jack plugs. The voltage between the pins may lead to severe damage!

3 INS

The INSERT is a break point in the input channel signal path. It allows the signal to be taken out from the mixer, through an external equipment such as a compressor, and than back to the mixer to continue the final mix output.

4 LOW CUT

With the Low Cut-switch, you can activate the high pass filter. This filter red frequency noise like microphone punch, closetalk, stage noise etc. With 75Hz and 18 dB/octave. The bass filter works independently from the equalizer settings.

5 GAIN

This rotary knob adjusts the channel signal level. Too high, the signal will distort as it overloads the channel. Too low, the level of back hiss will be more noticeable and there might be insufficient signal level to the output of the mixer. Proper gain setting allows the mixer to work in the best operating level, adjusts the gain when signal presents to the highest level without triggering the peak LED. That is the most appropriate position.

6 EQUALIZER

HIGH

With the HIGH-control, you can increase or lower the treble of the input signal at the respective channel. This is a 12KHz shelving equalizer with a control range of +/-15dB.

LOW

With the LOW-control, you can increase or lower the bass of the input signal at the respective channel. This is a 80Hz shelving equalizer with a control range of +/-15dB.

MID

With the MID-control, you can increase or lower the mids of the input signal at the respective channel. This is a shelving equalizer with a control range of +/-15dB, however it's central frequency can be changed by adjusting the "MID FRQ" knob.

MID FRQ

With this control, you can adjust MID-control frequency between 100Hz and 8KHz.

● MONO CHANNEL SECTION

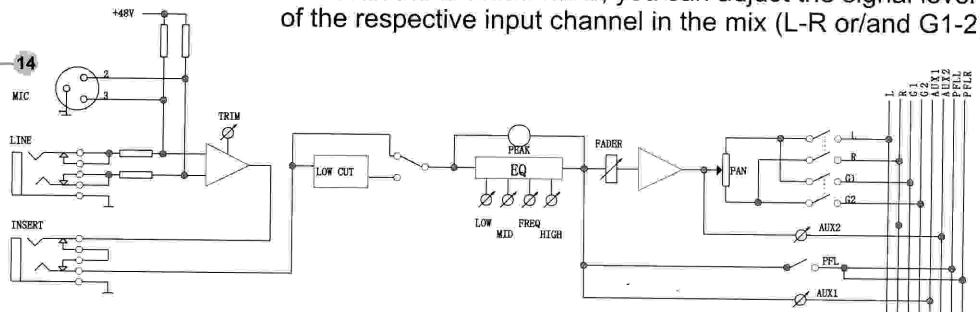
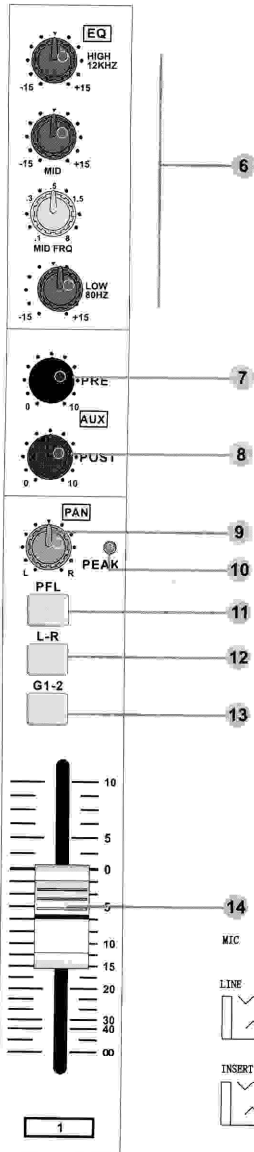
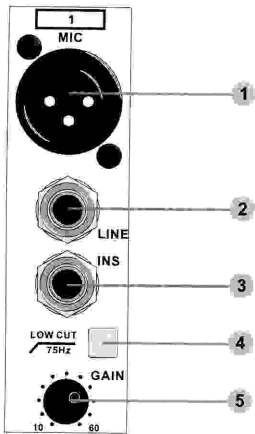

The schematic diagram for MONO channel

7 PRE

With the PRE-control, you can control the signal sent to the AUX SEND 1-socket. The signal is pre-fader and can be used for stage monitors or musician headphones.

8 POST

With the POST-control, you can control the signal sent to the AUX SEND 2-socket. The signal is post-fader and can be used for sending to an effector outside or to the DSP processor in the unit.

9 PAN

This control sets the amount of the channel signal feeding the left and right mix bus, allows you to locate the source smoothly across the stereo image.

10 PEAK

This red LED will warn you when an excessively high signal level is present in the channel. The signal is sampled at two points in the channel, immediately after/before the channel equalizer. The peak LED will illuminate approximately 6dB before clipping and therefore give warning of a possible overload.

11 PFL

With the PFL-switch, you can route the channel signal to the PFL-bus, in this way, you can make the signal level visible via the LED-meter or be monitored via the headphones or control room speakers.

12 L-R

With the L-R-switch, you can route the signal to the Main Mix fader, if you want to mute a channel, set the L-R-switch to unpressed position. Please note that the AUX-signals cannot be muted this way.

13 G1-2

With the G1-2-switch, you can route the signal to the group-bus. In this way, you can sum up different input channels into one group, e.g. Drums, winds or background singers.

14 Channel fader

With the channel fader, you can adjust the signal level of the respective input channel in the mix (L-R or/and G1-2)

The Stereo channel

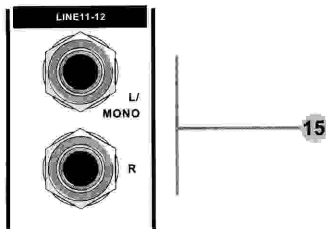

15 STEREO INPUT

This series of mixer has four groups of stereo line input sockets, any group of inputs can accept one stereo line signals via balanced or unbalanced jack plugs. If the source signal is mono only connect to the L/MONO socket.

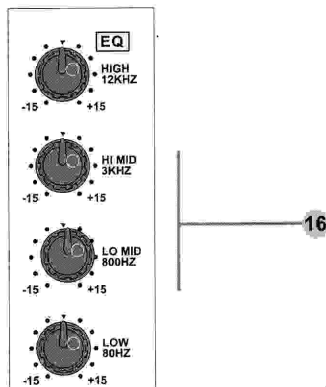

16 HI MID/LO MID

With the MID-control, you can increase or lower the mids of the input signal at the respective channel. The HI MID-equalizer is a 3 KHZ shelving equalizer with a control range of +/-15dB, and the LO MID-equalizer is a 800HZ shelving equalizer with a control range of +/-15dB.

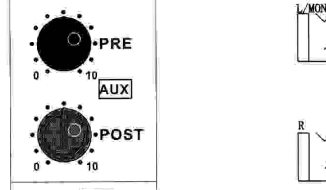

17 BAL(BALANCE)

The BALANCE control sets the amount of the channel signal feeding the MAIN mix output, allows you to balance the source in the stereo image. When the control knob turns fully to the left or right, you send only that side of the signal to the mix.

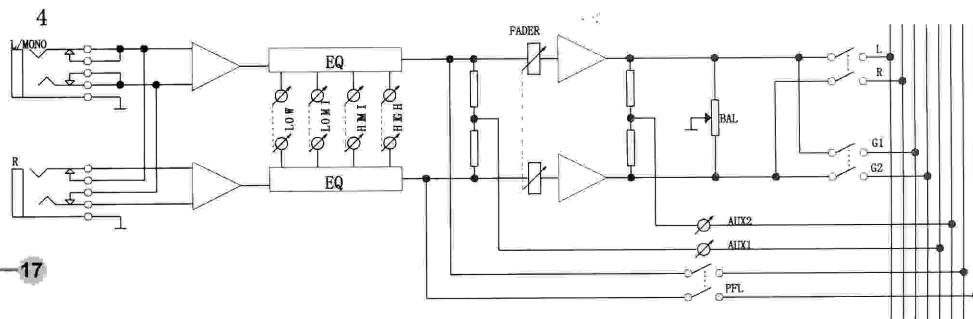

The schematic diagram for stereo channel

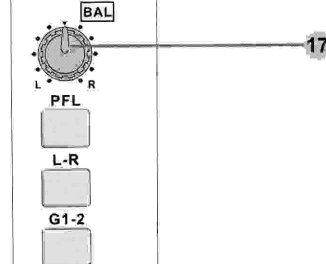

18 +48V PHANTOM

+48V Phantom voltage will be added to the input connector on each microphone input channel when pressed this switch, it allows you using condenser microphone.

All fader should be all the way down when switching on/off the Phantom power, in order to prevent excessive noise to stage monitor speakers and main speakers; Phantom powered Mics should not be plugged in with the +48V switched on.

Never turn on the phantom power when you have line level source connected to the input connector of the microphone input channel.

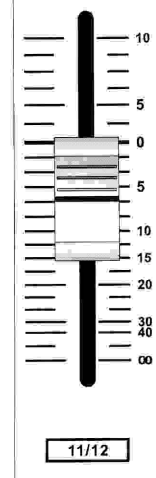

19 TAPE IN / USB IN

The signal linked TAPE IN from tape player or other sources will be amplified and adjusted inside, than will be feed to the mix L/R bus. This knob we mean is just used for controlling the signal level which will be feed to mix bus.

For CS-U series, this knob also controls the signal level come from the inner USB audio interface.

● MASTER SECTION DESCRIPTION

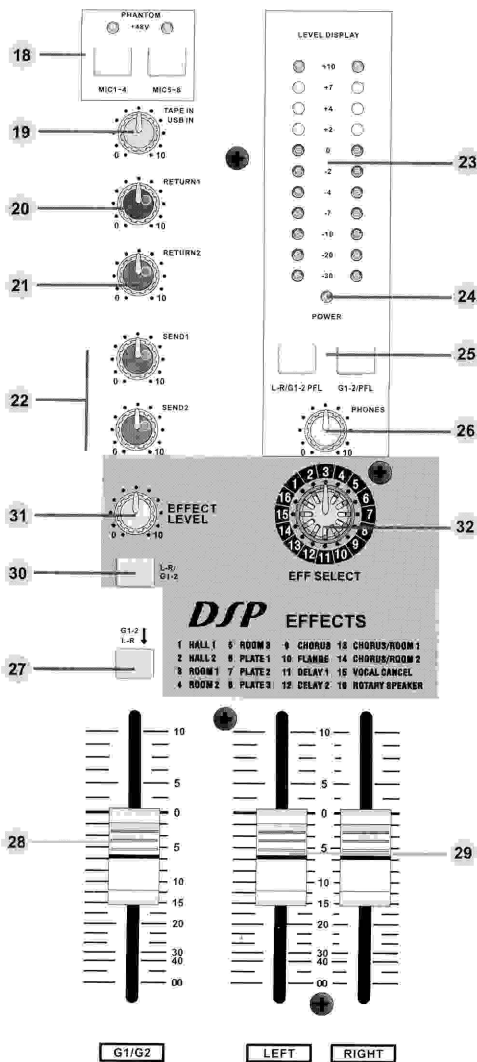

20 RETURN1

This knob allows you adjusting the signal levels feed to the L-R-bus, the signals are from the STEREO AUX RETURN1 jacks, usually sent by an external effector. Howerer AUX RETURN1 jacks also can be used as an stereo line inputs for other supplementary.

21 RETURN2

This knob allows you adjusting the signal levels feed to the L-R-bus, the signals are from the STEREO AUX RETURN2 jacks, usually sent by an external effector. Howerer AUX RETURN2 jacks also can be used as an stereo line inputs for other supplementary.

22 SEND1/SEND2

With the AUX SEND-controls, you can adjust the output level of the AUX SEND-sockets.

23 LED LEVEL METER

This LED level meter is made of 22 LEDs, it shows the level in logarithm mode, and has a peak-hold function. It can show via selectors:

1. Master output level
2. Group output level
3. The signal level from PFL-bus

24 POWER

This LED will be light, when power on.

25 L-R/G1-2 PFL & G1-2/PFL

With the L-R/G1-2 PFL switch, you can switch the LED meter from master signal to group signal or PFL signal.

With the G1-2/PFL switch, you can switch the LED meter from group signal to PFL signal.

The signals showed on LED meter and the signals feed to headphones and control room are same.

26 PHONES

With the PHONES-control, you can adjust the output signal of the PHONES-socket and CTRL R OUT-sockets.

27 G1-2 >L-R

Press down this button, you can route the group signal to the main mix fader.

28 G1/G2 FADER

This 60mm-length slide fader controls the output signal of the GROUP OUT-sockets.

29 LEFT/RIGHT FADER

LEFT slide fader controls the output signal of the MAIN OUT LEFT- sockets, and RIGHT slide fader controls the output signal of the MAIN OUT RIGHT-sockets.

30 L-R/G1-2

Release this button, the inner DSP effector is added to Master system; press down this button, the inner DSP effector will be added to the group system.

31 EFFECT LEVEL

This knob allows you adjusting the signal levels feed to the L-R-bus or G1-G2-bus, the signals come from the inner DSP effector with 16 kinds of effects, this controls is usually named effect depth control.

32 EFF SELECT

This switch is used for selecting one from 16 kinds of effects.

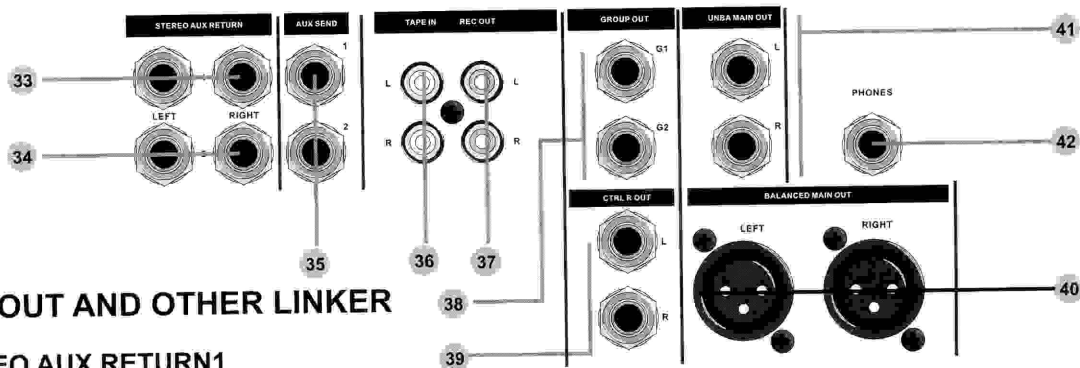

● MAIN OUT AND OTHER LINKER

33 STEREO AUX RETURN1

These two jacks are balanced, they usually are used as the stereo return inputs of the external effector, also can be used for other sources with line level, the stereo signals received here will be feed to the stereo main bus via RETURN1 fader.

34 STEREO AUX RETURN2

RETURN2 has same functions as RETURN1.

35 AUX SEND

They are unbalanced jack sockets, they all send out the AUX signals, AUX1 signal is fetched in front of the channel fader and AUX2 signal is fetched after the channel fader, so AUX2 signal is usually used as an input signals of an external effector.

36 TAPE IN

These two RCA jacks are used as stereo inputs for tape player or CD player, of course other line level sources also send signal to the mixer via these jacks.

37 REC OUT

The signals are sent to the tape recorder via the associate RCA sockets.

38 GROUP OUT

Via the GROUP OUT-sockets, you can connect the group signal with a headphones amplifier, e.g. For the background singers. You can adjust the signal level via the group fader.

39 CTRL R OUT

Via the CTRL R OUT-sockets, you can either connect active speaker-systems or an additional amplifier for a separate Control Room/monitor system.

40 BALANCED MAIN OUT 41 UNBA MAIN OUT

This mixer has two groups of MAIN OUT sockets, 2 XLR connectors for balanced main out, and 2 phone jacks for unbalanced. Their signals are all from the main-bus, left and right signals can be controlled independently.

42 PHONES

Via headphones you can monitor the main out or group out or the signals selected by channel PFL switch, the signal you hear just like you see on the LED meter.

REAR PANEL

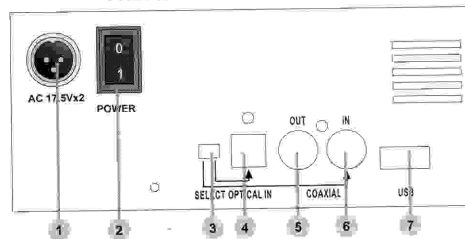

1 POWER SUPPLY INPUT SOCKET

Connect the special power supply unit to this socket. Make sure the power supply unit is not plugged into AC outlet before connecting to the mixer.

2 POWER ON/OFF SWITCH

This switch turns the power of the mixer on and off.

3 SELECT(only for CS-U series)

This switch selects one of the two signals optical in or coaxial in, usually this is a digital signal with PCM format, the signal will be sent to a computer to be record ,edited ,saved or format exchanged via USB port.

4 OPTICAL IN(only for CS-U series)

This Toslink jack can receive a digital signal via a fiber optic cable from a audio source with optical out.

5 COAXIAL OUT(only for CS-U series)

This RCA jack can carry a digital signal via a video cable to an audio equipment with coaxial in, for example, to an active sound box.

6 COAXIAL IN(only for CS-U series)

This RCA jack can receive a digital signal via a video cable from a audio source with coaxial out.

7 USB(only for CS-U series)

This USB jack is a communication port by which the USB audio interface of the mixer can carry data with a computer, their communication rule accords with international standard USB1.1 . The computer in use do not need any drive soft, plug and play, also it provides power for the USB audio interface at the same time.

● GENERAL SPECIFICATIONS

Inputs		Input modes	Connector	Input impedance	Rated input level
Mono Mic(Line) inputs	4/8/12	Balanced	XLR(3-poles TRS)	2Kohm(20Kohm)	-60dB(-40dB)
Stereo Line inputs	4	Balanced	2 3-poles TRS	10Kohm	-10dB
Stereo Aux Return	2	Balanced	2 3-poles TRS	10Kohm	-10dB
Stereo Tape in	1	Unbalanced	2 RCA	10Kohm	-10dB

Outputs	Number	Outputs modes	Connector	Outputs impedance	Rated output level
Stereo main outputs	1	Balanced	2 XLR	100ohm	+10dB
Stereo main outputs	1	Unbalanced	2 TRS	100ohm	+4dB
Stereo group outputs	1	Balanced	2 3-poles TRS	100ohm	+10dB
AUX send	2	Unbalanced	TRS	100ohm	0dB
Stereo REC out	1	Unbalanced	2 RCA	600ohm	-10dB
Control Room out	1	Unbalanced	2 TRS	100ohm	+4dB
Phones out	1	Stereo out	3-poles TRS	100ohm	3mW @36ohm

Equalizer	Modes	Max boost or cut	Frequency points
Mono channel EQ	Mono 3-band(PEQ for mids)	+/-15dB	80Hz,100~8KHz,12KHz
Stereo channel EQ	Stereo 4-band	+/-15dB	80Hz,800Hz,3KHz,12KHz

Max gain	Signal route	Conditions
76dB	MIC IN-----ST BAL MAIN OUT	@10Kohm load balanced out
70dB	MIC IN-----ST UBA MAIN OUT	@10Kohm load unbalanced out
76dB	MIC IN-----ST BAL GROUP OUT	@10Kohm load balanced out
74dB	MIC IN-----AUX SEND1	@10Kohm load
72dB	MIC IN-----AUX SEND2	@10Kohm load
57dB	MIC IN-----INSERT	@10Kohm load
53dB	MIC IN-----REC OUT	@1Kohm load
67dB	MIC IN-----CTRL R	@10Kohm load
58dB	MIC IN-----PHONES	@32ohm load
51dB	MONO LINE IN-----UB MAIN OUT	@10Kohm load balanced out
21.5dB	ST LINE IN-----UB MAIN OUT	@10Kohm load balanced out
21.5dB	TAPE IN-----UB MAIN OUT	@10Kohm load balanced out
21.5dB	AUX RETURN-----UB MAIN OUT	@10Kohm load balanced out

Total harmonic distortion	<0.1%	@+14dB	20~20000Hz (ST OUT L/R, AUX OUT @620ohm)
Frequency response	+1/-2dB	@+4dB	20~20000Hz (ST OUT L/R, AUX OUT @620ohm)
Max out level	+20dB/+26dB<Bala>	@0.5%THD	1KHz (ST OUT L/R, AUX OUT @620ohm)
Microphone preamp E.I.N	<-124dB	@ 150ohm terminated,	max gain(ST OUT L/R @620ohm)

Type	CS-1222/CS-1222U	CS-1622/CS-1622U	CS-2022/CS-2022U
Power	AC 230V, 50Hz		Use adapter
Power consumption	14.1VA	15.6VA	17.2VA
Weight (Kg)			
Dimensions(mm)			

STANDARD CONNECTIONS (Example CS-1622)

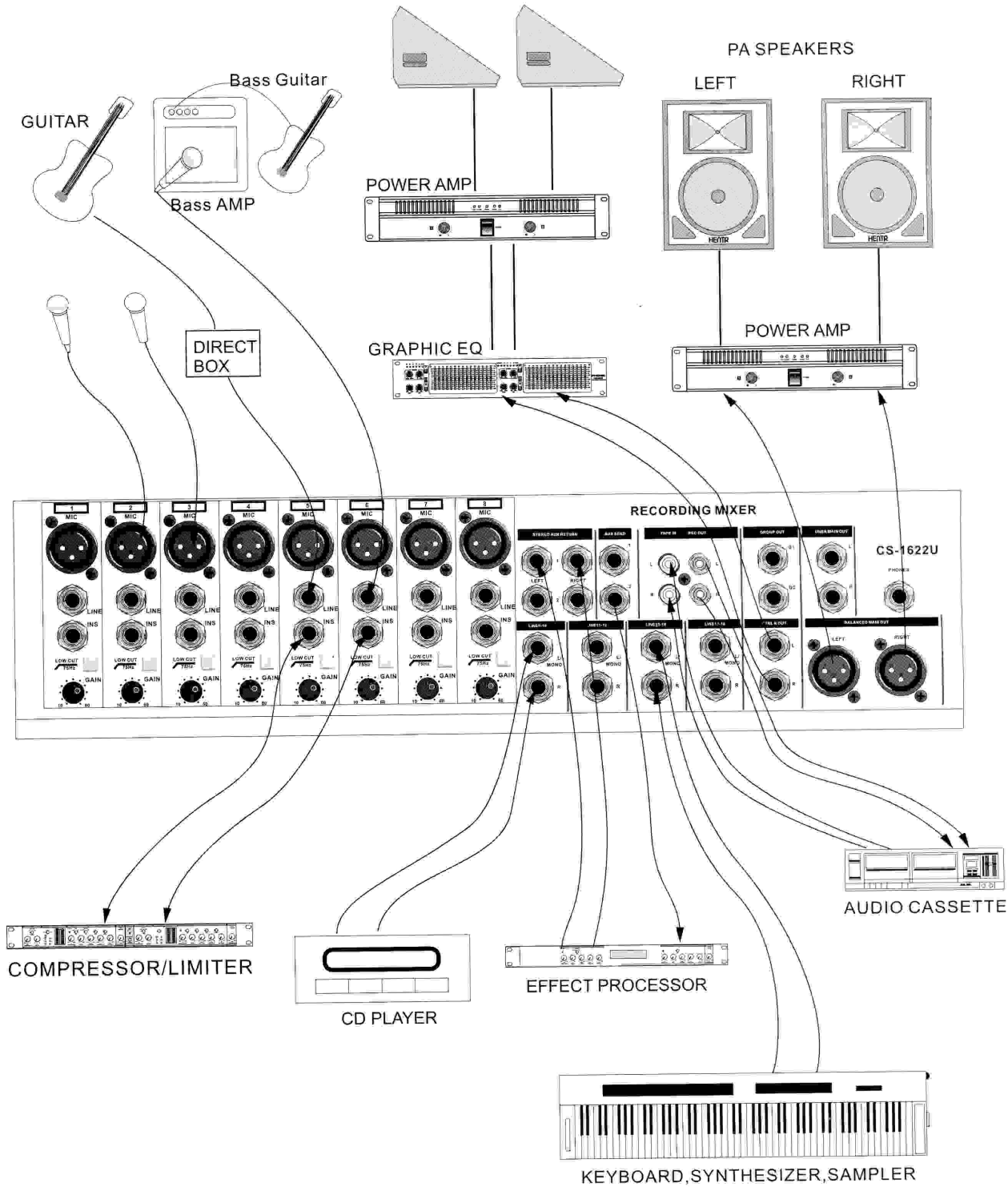

SYSTEM BLOCK DIAGRAMS

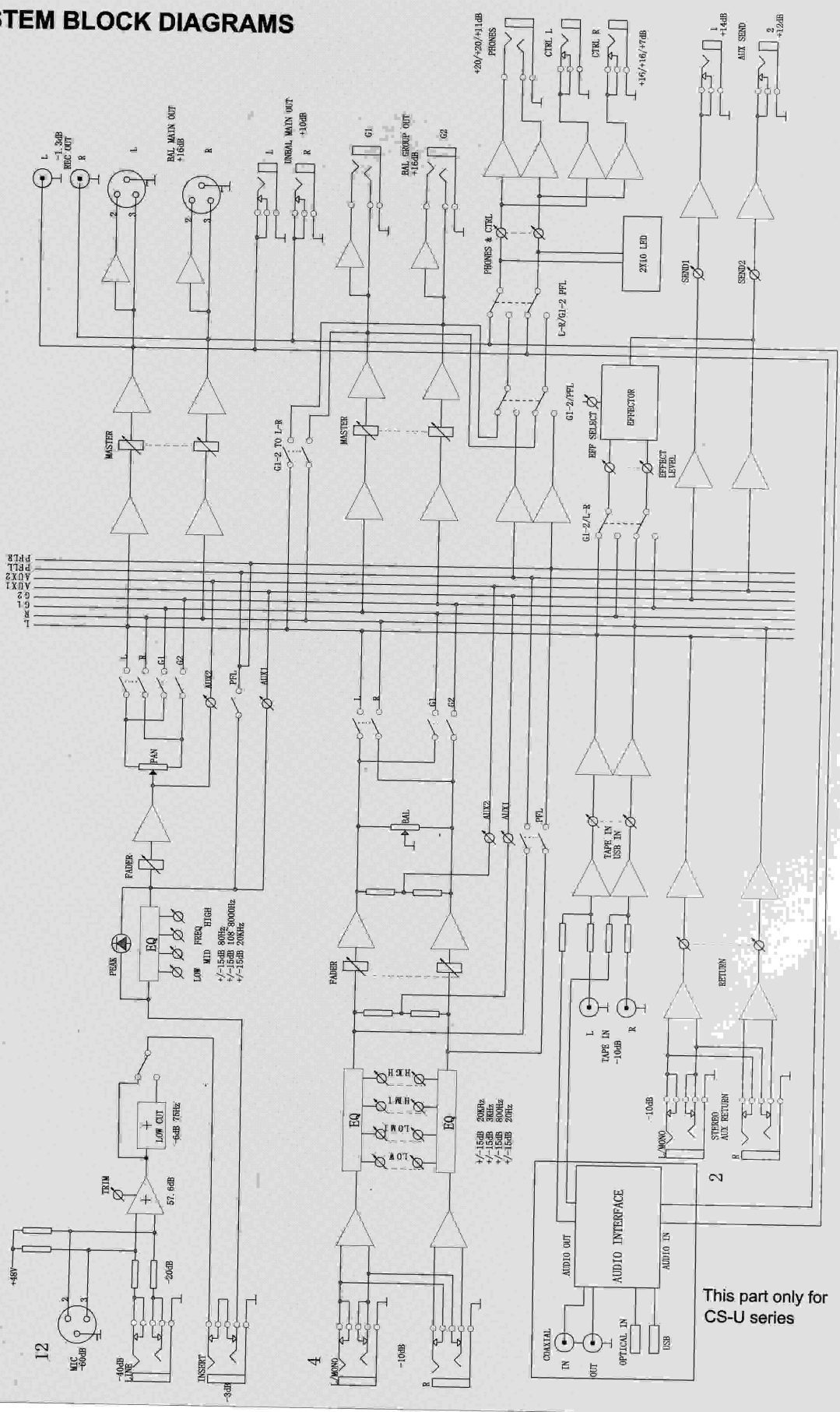

This part only for CS-U series