

Professional MULTIBAND SOUND ENHANCEMENT PROCESSOR

OWNER'S MANUAL

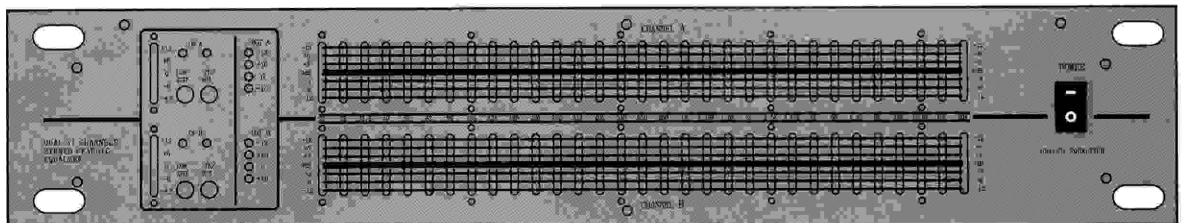

声明:在使有此系列产品之前,请认真阅读有关的操作使用方法
 Declare: Before attempting to connect, operate or adjust this product, please read these instruction completely

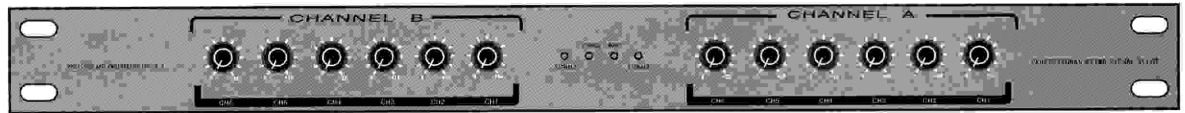
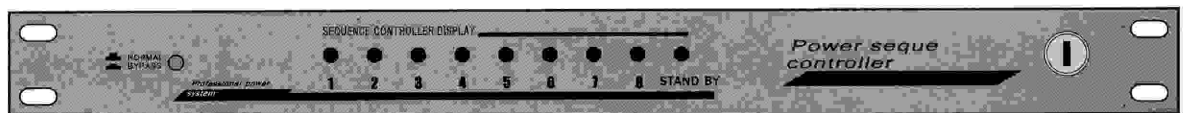
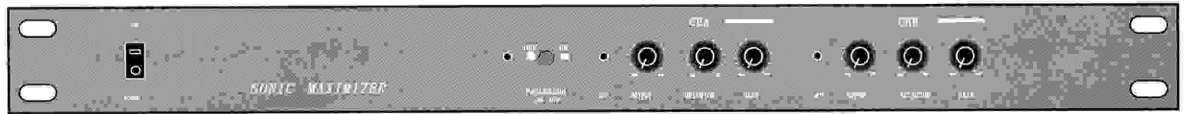
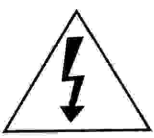

等边三角形内带有箭头的闪电符号是用来提醒用户在产品的外壳上存在可能会给人体造成相当程度的触电危险的未绝缘危险电压。

The symbol of arrowhead in the equilateral triangle is used for reminding users that the product's crust may exist some uninsulated dangerous voltage that can bring your body certain levels'electric shocking.

CAUTION

注意：为防止触电危险，请勿卸下盖子（或背面板）。内部没有用户可能进行维修的零部件。维修应委托有资质的维修人员进行。

Caution: to prevent the danger of electric shocking, please don't open the cover (or the rear panel) there are some parts that you may not be able to fix please ask a qualified.

**RISK OF ELECTRIC SHOCK
DO NOT OPEN**



等边三角形的感叹号是用来提醒用户本机存在用文章表示的重要的操作个维修(检查)指示。

The exclamation mark in the equilateral triangle is used for reminding you that this product has some important instructions that made in articles For operation'maintenance(Examining).

请遵守下列事项以避免本机出现故障或引起严重损坏。

Please follow the attentions below to avoid aborts or certain deformations of this product.

For the safe of using, Please pay attention to the instructions below:

为了操作安全, 请注意下列事项:

湿度 There may agglomerate humidity for testing Inside it.

- ★ 当热空气与冷空气接触时, 将凝聚湿气(露水)例如冬天温暖的房间的窗子。
When warm air meets hot air, it agglomerates the humidity(dew),
Such as the window in a warm house at winter.
- ★ 下列情形下, 本机内可能回凝聚湿润气:
It may agglomerate humidity when these things below happened:
- ★ 本机在刚打开暖气, 有蒸气或高温的房间内。
When it just opens the heating oven in a room with steam or high temperature.
- ★ 本机从寒冷的环境中被带到充分加热的房间内, 特别是冬天。
If you bring it from the cold surroundings into a room that it is heating enough, especially at winter.
- ★ 本机从凉爽的环境中, 例如有空调的房间或车内, 突然带到很热和潮湿很重的地方。
If this product in one of the statement above, use it again when it is sure
It is very hot and with high moisture.
- ★ 如果本机凝聚了湿气, 则本机有可能不能正常工作
If this product has agglomerated humidity then it may not work well.
- ★ 如果本机处于上述条件之一, 则请确认无湿润气形成之后使用本机。
If this product in one of the statement above, use it again when it is sure
without any humidity.

使用 Using Instructions

- ★ 从电源插座拔掉电源线时, 请握住插头, 而不要拉扯电线。
When you want to pull out the power line from the socket please hold the plug but not pull the line.
- ★ 请使电源线远离加热设备。
Please make sure the power line is far a way from any heating facility.
- ★ 请勿在电源线上堆放重物。
Please don't put anything heavy on the power line.
- ★ 请勿试图修理或改装电源线。
Please don't attempt to fix or re fit the power line.

- ★ 请使本机远离水源，例如水槽，澡盆等。
Please make sure this product is a way from water ,such as flume, bathtub and so on.
- ★ 请勿取下外壳。
Please do not take off the crust
- ★ 接触机内部件极其危险，可能会引起本机的严重故障。
It is quite dangerous to touch the parts inside ,it may cause serious aborts of this product.
- ★ 雷雨不得使用时，请尽快从电源插座拔掉电源线。
Do not use this product when it is thunderstorm Please hurry to pull off the power line from the power socket.

安装 Install

- ★ 请将本机放置于平坦，稳定和通风良好的地方。
Please place this product in a place that it is flat ,steady and with excellent ventilation.
- ★ 操作中本机器将略发热，但不属于故障。
It may hear a bit when operating this product ,but it is not any situation of abort.
- ★ 请勿将本机放置于下列地方：
Please do not place this product in the places below:
长时间暴露于直射阳光的房间内。
A place in the room that it is always shined directly.
近强光源或热源。
Close to any strong light or heat.
蒸气或灰尘或湿度大或油烟的地方。
The place has much steam, dust ,high at humidity, with oil and smoke.

清扫 Cleaning

- ★ 请用柔软，清洁的布擦拭本机外壳。
Please use soft,clealy cloth to wipe the crust of this product.
- ★ 请勿用挥发性溶液，例如：酒精，涂料稀释剂，挥发油等。
Please do not use any volatility solution , such as alcohol , paint thinner , naphtha and so on.
- ★ 对于顽固斑点，请用柔软的布加上中性洗涤剂擦拭，然后用干燥的布擦拭。
As that kind of spot that can be clean easily, please use soft cloth without any neutral detergent to clean it, and then wipe it with a dry cloth.

放置 Placed

- ★ 请勿在本机上放置重物。
Please do not place any heavy on this product.
- ★ 移动本机时：
When you move this product:
请小心勿掉落本机或遭到强烈撞击。
Please be careful and make sure that won't drop it on land or hit something heavily.
确认本机所有的连接线都被拔掉。
Make sure that all attached lines have been pulled out.

关于再包装 About packing again

包装箱和包装用材料最好保持下来，以便以后再装运时使用。
You'd better keep the packing case and the stuff for packing in case you can use them again when you want to pack and move this product.

附件 Annexes

说明书，保修卡。
Instruction book the card guaranteed for repairing.

PRO AUDIO SYSTEMS

衷心感谢您购买我们公司的产品

为了得到最佳性能并保证装置长久不出毛病,首先请仔细阅读这本使用说明书,在您读完这本说明书之后,请将它存放在一个安全的地方,以便以后参考。

某些地方使用的电源插头后电源插座,能了解释图中所见到的不一样,不过,连接和操作本机的方法还是一样。

警告:别让本机接触到雨水或者潮湿,以防发生火患或者触电的危险。

Heartfelt thanks for purchasing our product.

Incase for the best performance and make sure this set won't go Wrong for along time , please red this instuction book carefully Beforehand .After reading,,pkease keep it on safe place in case You can read it again in the future.

Some power plugs or power sockets may be not as same as the ones Showed in keydrawing ,but with the same method of connect and Operate this product.

Caution: please do not let this product touch with water or Moisture ,in case that it occure danger like catching fire Or electric shocking.

注意事项	1-2
Matters needing attention	
前列. 目录	3
content	
压缩限幅器	4-5
Compression amplitude limiter	
电子立体声二频, 单声道三分频	6
Electronic two frequency dividers	
激励器	7-9
Maximizer	
电源时序器	10-11
Power Sequence controller	
信号分配器	11-12
Singnal Alloter	
卡拉OK前置效果器	13-14
Kara OK pretage effect	
均衡器	15
Equalizer	

双通道压缩限幅器

DUAL CHANNEL COMPRESSOR/LIMITER WITH GATE

CL-8000压缩/限幅器，采用Auto-Limit(自动压限)上升和恢复电路，最新的程序自动扩转噪声门电路。自动懂得分析不同的节目而运算一个最平滑的恢复特性，而更阔的动态，更准确的放大线性，更使CL-8000达到非一般的压缩/限幅效果。

特设Stereo/Mon联路开关，方便调整左右声道的统一效果；输入电平选择 (+4/-10dBu)；

LED指示灯准确显示当前信号电平变化，令操作和调整更加简易。

Uses limits from the dynamic pressure rises and restores the electric circuit, the newest procedure expands automatically transfers the noise gate.

Understood automatically the analysis different program operates a smoothest restoration characteristics but a more extravagant tendency, the more accurate enlargement linearity enables CL-8000 to achieve non-general compression/restriction effect

面板介绍 Front panel instruction

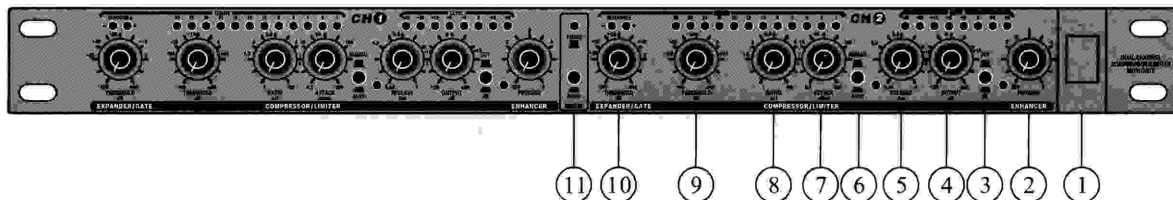

1. 电源开关
power switch
2. 外接控制, 编程控制
External connection control,
programming control
3. 直通测试开关
Goes nonstop to the test switch
4. 输出音量
Output volume
5. 压缩复位时间
Compression resetting time
6. 手动, 自动开关
Manual, autoswitch

7. 控制启动时间
Control starting time
8. 压缩比例
Compression proportion
9. 压缩分贝
Compression decibel
10. 噪声门
Noise gate
11. 立体声/单声道开关
Stereo sound/single
track switch

背后板介绍 Rear panel instruction

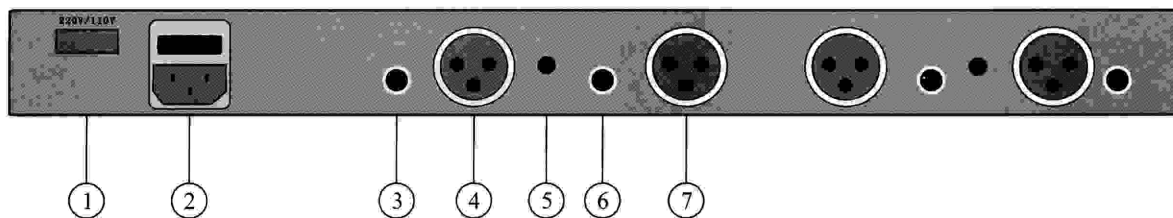

1. 110V/220V转换开关 Change-over switch
2. 电源 Power
3. 编程控制输入 Programming control input
4. 平衡信号输出 Balanced signal output
5. -10dB/+4dB按钮 -10dB/+4dB Button
6. 不平衡信号输入 Unbalanced signal input
7. 平衡信号输入 Balanced signal input

技术参数: Technical specifications

输入 INPUT

类型 Type	Therefore filtered , servo-balanced input
连接器 Linker	XLR and 1/4' TRS jacks
阻抗 Impedance	50K Ohms balanced 25K Ohms unbalanced
正常操作电平 Normal operation level	+4 dBu/-10dBV seitchable
最大输入电平 Biggest input level	+21 dBV balanced and unbalanced
CMRR	typically 40dB,>55dB@1kHz

检测器输入 Detector input

类型 Type	DC de-coupled unbalanced input, 1/4' TRS jack
阻抗 Impedance	> 20k Ohms
最大输入电平 Biggest input level	+ 21dBu

输出 OUTPUT

类型 Type	Electronically buffered output stage
连接器 Linker	XLR jacks
阻抗 Impedance	60 Ohms balanced 30 Ohms unbalanced
最大输出电平 Biggest input level	+21dBu balanced and unbalanced
频道宽度 Channel width	20Hz to 20KHz,+0/-0.5dB
频率响应 Frequency response	0.35Hz to 200kHz,+0/-3dB
噪音 Noise	>-95dBu,unweighted,22Hz To 22Kz
总谐波失真 Total harmonic distortion	0.04%typically @+4dBu,1kHz,Gain 1
互调失真 Intermodulations the distortion	0.01%typically SMPTE
转线路 Cross-over	<-100dB,22Hz to22kHz
立体变程 Three-dimensional range	True RMS detection
CMR@IKHz	>60dB

增大器/传播器部分 Increases/the dissemination part

类型 Type	IRC(Interactive Ratio Control)Expander/Gate
界限 Boundary	variable(OFF to+10dBu)
起音 Has the sound	<1ms/100dB
释放 Release	100m/100dB

压限器部分 The pressure limits the part

类型 Type	IKA(Interactive Knee Adaption)Compressor
界限 Boundary	variable(-40to+20dBu)
比率 Ratio	variable(1:1to8:1)
开端特性 Beginning characteristic	Hard Knee
手动起控时间 Manual controls the time	variable(0.1to200ms/20dB)
手动释放时间 Manual release the time	variable(0.05to4sec/20dB)
自动起控时间 automatically controls the time	typ. 15ms.@10dB,5ms@20dB,3ms@30dB
自动释放时间 automatically release the time	program dependent,try.125dB/sec
输出 output	Variable(-20to+20dB)

激励器部分 Sonic Maximizer part

类型 Type	Dynamically controlled frequency correction
操作 Operation	variable(-20to+20dB)

功能开关 Function switch

输入/输出 Input/Output	Bypass switches both chnnels
自动 Automatic	Program-dependent attack and release times
显示器 Monitor	1/2/4/6/9/12/15/18/21/24/27/30dB
12段增益 12 sections of gains	-30/-20/-10/-6/-3/0/+3/+6dB
仪器表 Measuring appliance	
8段点平表 8 section of spot even tables	
没一个功能开关的发光二极管显示器 Not a function switch's light emitter diode monitor	
无声发光二极管 Silent light emitter diode	"+" / "-" indicates onset of the Expander/Gate

电源供给 Power supply

交流电电压 Alternating current voltage	100-120/60Ha or 200-240/50Hz VAC selectable
电源消耗 Power source consumption	9 watts
保险丝 Fuse	T250mA,250V
电源线连接 Power line coupling	Standard IEC receptacle
尺寸 Size	1.75" × 19" × 6.5" (44 × 482 × 165mm)
重量 Weight	4.4lbs.(2.2Kg)

立体声二分频 单声道三分频器

Stereo sound two frequency divisions Single track three frequency dividers

前面板指示图 Front panel indicator card

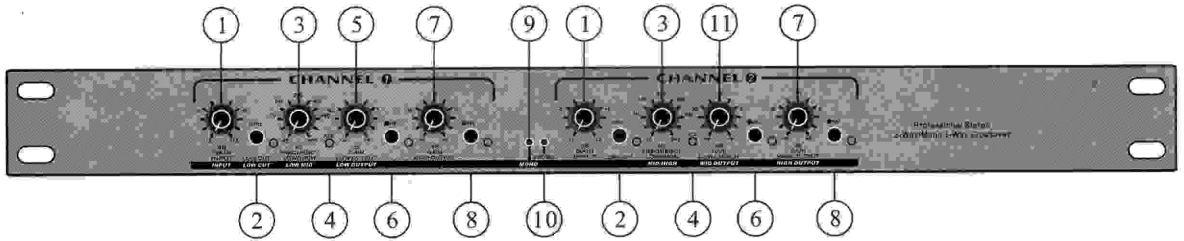

- | | |
|--|--|
| 1. 输入增益调整 The input increases dodges the adjustmen | 7. 高频输出增益调整 High frequency output gain control |
| 2. 40Hz过滤开关 40HZFilters the switch | 8. 高频相位转换开关 High frequency phase change-over switch |
| 3. 分频调节点控制 Frequency division adjustment control | 9. 单声道指示灯 Single track indicating lamp |
| 4. 分频调节10倍指示 The frequency division adjusts 10 time of instruction | 10. 双声道指示灯 Dual track indicating lamp |
| 5. 低频输出增益调整 Low audio-output gain control | 11. 低中频输出增益调整 Low intermediate frequency output gain control |
| 6. 低频相位转换开关 Low frequency phase change-over switch | |

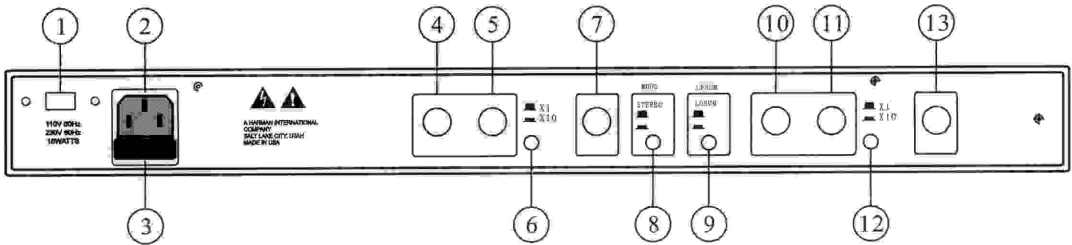

- | | |
|---|---|
| 1. 交流电压选择开关 Alternating voltage selection switch | 8. 单/双声道选择开关 Single/Dual sound track selection switch |
| 2. 交流电源输入 Alternating current supply input | 9. 低频增益开关 Low frequency gain switch |
| 3. 保险管盒 Protective tube box | 10. 第1通道高频输出口 1st channel high frequency output |
| 4. 第2通道高频输出口 2nd channel high frequency outlet | 11. 第1通道低频输出口 1st channel high frequency output |
| 5. 第2通道低频输出口 2nd channel low frequency outlet | 12. 分解调整10倍选择开关 The decomposition adjusts 10 time of selection switches |
| 6. 分频调整10倍选择开关 The frequency division adjusts 10 time of selection switches | 13. 第一通道声音输入口 First channel input port |
| 7. 第2通道声音输入口 2nd channel input port | |

SPECIFICATIONS

技术参数: Technical specifications

- | | |
|--|---|
| 分频器类型 Frequency divider type | Stereo 2ways/Mono 3ways |
| 分频范围(立体声) Frequency division scope | Low/Mid:50Hz-5KHz;Mid/high:750Hz-7.5Khz |
| (单声道) Stereo sound/Single sound | Low/low-mid:50Hz-5KHz;Low-Mid/High-Mid:750Hz-7.5KHz |
| 滤波器类型 Filter type | High-Mid/High:2KHz-20KHz |
| 输入类型 input type | 18dB/Octave |
| 输入阻抗 input Impedance | Ban lanced/Unb lanced 1/4' |
| 输出 output | 20Kohms Unban ced 40Kohms ban lanced |
| 类型 type | Ban lan ced / Unbanlanced 1/4 |
| 阻抗 Impedance | 102 Ohms |
| 低削波过滤器 Low clipping filter | 40Hz/-3dB,18dB/Octave |
| 频率响应 Frequency response | 20Hz-25Khz +/-1dB |
| 总谐波失真(THD)噪音 Total harmonic distortion | <0.006% |
| 信噪比 Signal-to-noise ratio | >-95dB |
| 保险丝 Fuse | 0.5A/250V,5mm glass type |
| 尺寸 Size | 19 × 1.73 × 5.75(483 × 44 × 146mm) |
| 重量 Size | 4.0Ibs(2.0Kg) |

声音优化激励器/Sonic Maximizer

Sonic Maximzer/audio optimum processor.

A)专业的声频激励器,它可以对声音的中高频和低频进行独立的激励处理,使声音中高频更加清晰,细致,低音更加紧凑结实和有冲击力.

Is a professional audio exciter. It can deal with the driving management itself of the audio medium high frequency and the low frequency. Can make the medium high frequency much clearer, more delicate, and make the bass much compacter, more massive, and with more impact force.

C) 面板上的TUNE旋钮可以令声音中的中高频更清晰,细致,而BASS旋钮可以令声音的低频部分更加结实和有冲击力,两个旋钮配合使用可以形造出你所需要的特定音色.

The DEFINITION knob on the panel can make the medium high frequency in the sound much clearer, more delicate, and he BASS knob can make the low frequency in the sound much compacter more, massive, and with more impact force. Use these two knobs together can get any specially tamber you need.

B)使用面板上的PROCESS ON/OFF按键可以即时比较使用BBE处理和不使用BBE处理的区别,以便选择你更喜欢的音色.

Pressing the keystroke PROCESSOR ON/OFF on the panel can immediately know the differet between using BBE management or without using BBE management. N case that you can choose the tambei you like better.

面板介绍 Front panel instrution

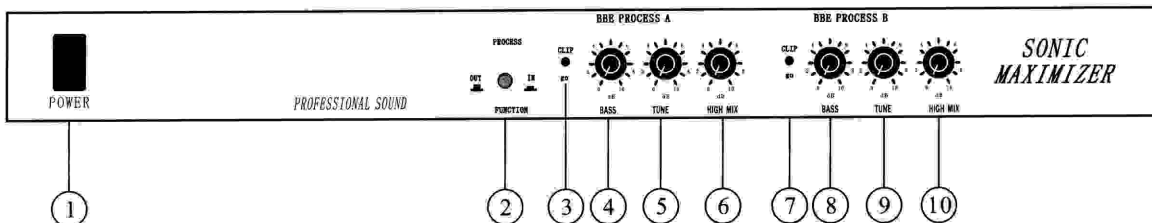

1. 电源/指示灯

Powreon LED

2. 直通/激励开关

BYPASS/PROCESS SWITCH

3. 通道A输入信号指示灯(红灯亮表示信号失真)

CH.Ainput signal LED

4. 通道A. 低音优化控制

Channel A output level adjust

5. 中音扫频

Definition control

6. 通道A高音优化控制

CH.Abass

7. 通道B输入信号指示灯(红灯亮表示信号失真)

CH.Binput signal LED

8. 通道B低音优化控制

CH.Bnnel output level adjust

9. 中音扫频

Definition control

10. 通道B高音优化控制

CH.B bass

面板介绍 Front panel instrution

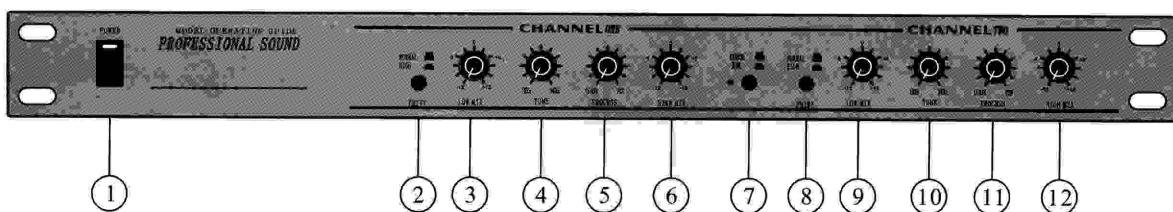

- | | |
|--|--|
| 1. 电源开关
Power switch | 7. 激励/直通开关 (红灯/绿灯)
Macimzer/through switch |
| 2. CH1通道低频加强增益开关 (红灯/绿灯)
CH1 low frequency change-over switch | 8. CH2通道低频加强增益开关 (红灯/绿灯)
CH2 low frequency change-over switch |
| 3. CH1低频增益
CH1 low-frequency gain | 9. CH2低音频增益
CH2 low audio gain |
| 4. CH1中音扫频
CH1 tenor scanning | 10. CH2中音扫频
CH2 tenor frequency sweep |
| 5. CH1清晰度提升
CH1 clarity promotion | 11. CH2清晰度提升
CH2 clarity promotion |
| 6. CH1高频增益
CH1 high frequency gain | 12. CH2高频增益
CH2 high frequency gain |

背后板介绍 Rear panel instrution

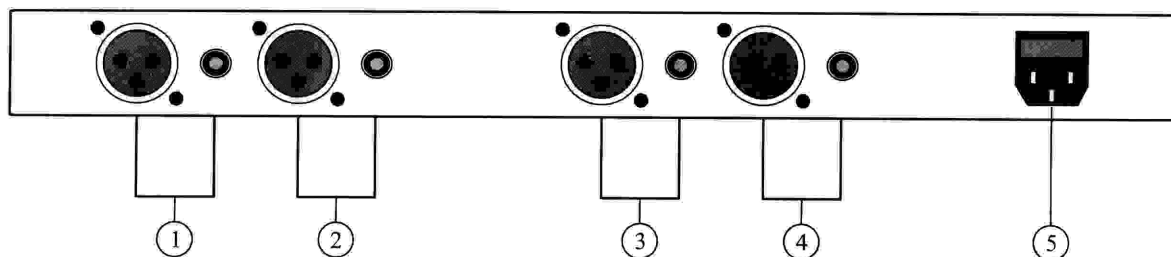

- | | |
|--------------------------------|---------------------------------------|
| 1. CH2通道声音输出插座
CH2 Output | 4. CH1通道声音输入插座
CH.B THROUGH |
| 2. CH2通道声音输入插座
CH.A through | 5. 电源输入连保险管插座
A C. input connector |
| 3. CH1通道声音输出插座
CH.B inputs | |

技术参数: technical specifications

输入 INPUT

连接器 linker	XLR and 1/4"TRS jacks
类型 Type	Rffiltered,servo-balanced input
阻抗 Impedance	+/-12k ohms
最大输入电平 Biggest input level	21 dBu balanced and unbalanced
CMRR	Typically 40dB,>55dB@1kHz

输出 OUTPUT

连接器 linker	XLR and 1/4"TRS jacks
类型 Type	Electronically buffered output stage
阻抗 Impedance	+/-45 Ohms balanced
最大输出电平 Biggest input level	+21 dBu balanced and unbalanced
频道宽度 Channel width	20Hz to 20KHz
频率响应 Frequency response	0.35Hz to 200kHz
噪音 Noise	>-95dBu,un weighted, 22Hz to 22kHz
互调失真 Intermodulations the distortion	0.01%typically,SMPTE
总谐波失真 Total harmonic distortion	0.045%typically@+4dBu,1kHz,Gain 1
CMR@1KHz	>60dB
频道扫描 Frequency scanning	1KHz to 8kHz
立体变程 Three-dimensional range	True RMS detection
清晰度提升 Clarity promotion	+6dB
最大低频增益 Most greatly low-frequency gain	+21 dBu balanced and unbalanced
最大高频增益 Most greatly high-frequency gain	+21 dBu balanced and unbalanced

电源共给 Power supply

电源消耗 Power source consumption	9watts
保险丝 Fuse	T250mA,250V
电源线连接器 Power line coupling	Standard IEC receptacle
交流电电压 Alternating current voltage	100-120/60Hz or 200-240/50Hz VAC selectable
尺寸 Size	1.75" × 19" × 6.5" (44 × 482 × 165mm)
重量 Weight	4.4ibs.(2.2kg)

8路电源时序控制器 8 group power source sequential control

A. 结构操作指示 Structure operation instruction

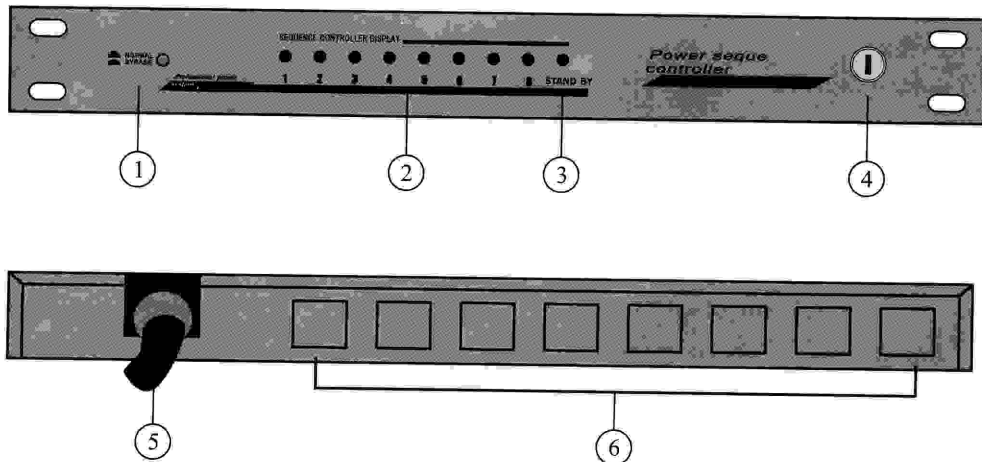

1. 备用电源开关: 可以用来以控制器因某些原因而失去控制, 关掉此开关, 可以同时连接所有插座的电源。
1. Emergency power supply switch: May use for to prevent and control the regulator to lose the control because of certain reasons, switches off this switch, may simultaneously connect all plug the power source.
2. 显示与输出插座情况: 当每个指示灯亮相对应插座就会连接通电源。
2. Demonstration and output socket situation: When each indicating lamp will present corresponds the plug company to put through the power source.
3. 电源指示灯: 打开了此电源控制器后, 指示灯就会显示已经启动的控制信号。
3. Power light: After having turned on this power source controller, the indicating lamp will demonstrate already started control signal.
4. 电源开关: 打开了此电源开关时, 就会自动按照: CH1-CH8 此顺序把电源输入插座中. 关掉了此电源, 就会自动按照: CH8-CH1 此顺序把电源切断。
4. Power switch: When has turned on this power switch, automatically will defer to: CH1-CH8 this order the mains input plug, has switched off this electricity the source. Automatically will defer to: CH8-CH1 this order power source cut-off.
5. 电源输入电缆。
5. Power source input cable
6. 电源输出插座。
6. Power source output socket

B. 功能与使用 Function and use

1. 当此电源开关打开了时, 控制器可以按顺序连接到每一个插座里. 相反地, 关掉此电源开关, 控制器可以反顺序切断每一个插座上的电源。
1. At this time the power switch when has opened, the controller may connect in each plug according to the order. On the contrary, switches off this power switch, controls to be possible the inverse order to shut off on each plug's power source.
2. 此装置可以用作音响系统, 电脑, 电视播放系统与其他电源系统, 都需要按顺序地打开的设备。
2. This equipment may serve as the sound system, the computer, the television broadcast system with other electrical power system, needs the equipment which opens according to the order

C. 技术规格 Technical norms

1. 每一路输出电流: 30A Each group output current :30A
2. 控制电源: 8通道 Control supply: 8 Channel
3. 通道间隔切换时间: 1秒 Channel gap switching time : 1 second

16路电源时序控制器

16 group power source succession controller

A. 结构操作指示 Structure operation instruction

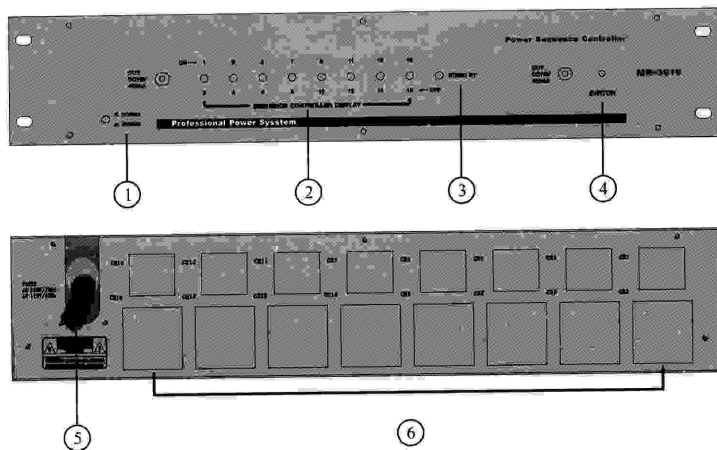

1. 备用电源开关:可以用来以防控制器因某些原因而失去控制,关掉此开关,可以同时连接所有插座的电源。
2. 显示与输出插座情况:当每个指示灯亮相对应插座就会连接通电源。
3. 电源指示灯:打开了此电源控制器后,指示灯就会显示已经启动的控制信号。
4. 电源开关:打开了此电源开关时,就会自动按照:CH1-CH16此顺序把电源输入插座中,关掉了此电源,就会自动按照:CH16-CH1 此顺序把电源切断。
5. 电源输入电缆。
6. 电源输出插座。

B. 功能与使用 Function and use

1. 当此电源开关打开了时,控制器可以按顺序连接到每一个插座里。相反地,关掉此电源开关,控制器可以反顺序切断每一个插座上的电源。
At this time the power switch when has opened, the controller may connect according to the order to a plug, on the contrary, switches off this power switch, the controller may the inverse order shut off on each plug's power source

2. 此装置可以用作音响系统,电脑,电视播放系统与其他电源系统,都需要按顺序地打开的设备。

This equipment may serve as the sound system, the computer, the television broadcast system with other electrical power system, needs the equipment which opens according to the order

C. 技术规格 Technical norms

1. 每一路输出电流:30A
Each group output current :30A
2. 控制电源:16 通道
Control supply :16 channel
3. 通道间隔切换时间:1秒
Channel gap switching time :1 second

音频信号分配器

Signal allot controller front panel instruction:

面板介绍 Front panel instrution

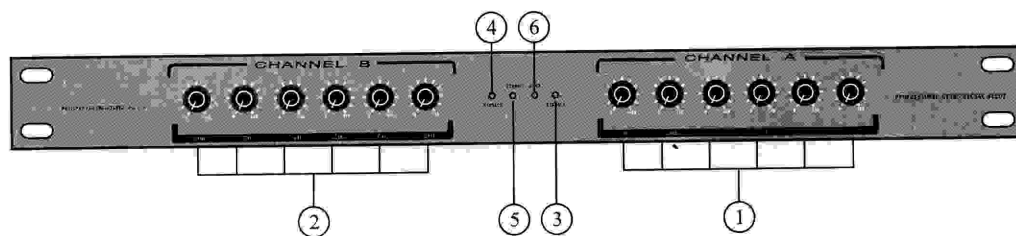

- | | |
|--|------------------------------|
| 1. 立体声A通道1-6输出电平控制
Stereo Output CHA Vol 1-6level | 3. A通道信号指示
Cha Signal Led |
| 单声道1-6输出电平控制
Mono Output Vol 1-6level | 4. B通道信号指示
Chb Signal Led |
| 2. 立体声B通道1-6输出电平控制
Stereo Output Chb Vol 1-6level | 5. 立体声指示灯(黄灯)
Stereo Led |
| 单声道7-12输出电平控制
Mono Outputvol17-12level | 6. 单声道指示灯(绿灯)
Stereo Lcd |

背面板介绍 Rear panel instrution

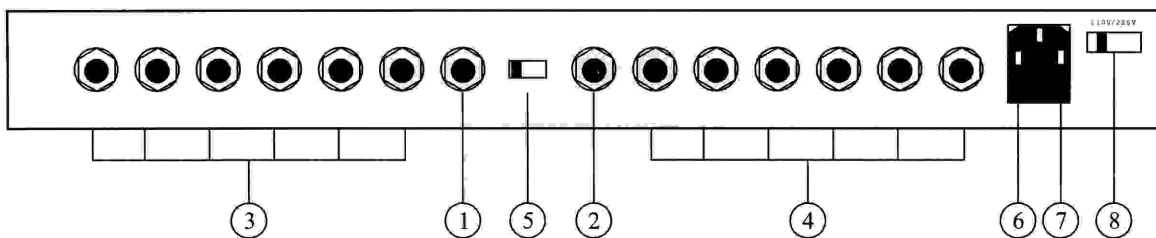

1. A通道声音输入

Cha linput

2. B通道声音输入

Chb input

3. 立体声A通道1-6输出

stereo Out Cha Out 1-6

单声道1-6输出

Mono Output Out1-6

4. 立体声B通道输出

stereo Output Chb Out1-6

单声道7-12输出

Mono Output Out7-12

5. 立体声/单声道开关

Mode Switch

6. 电源输入

AC Cord

7. 保险管(250MA)

fuse comm. parment

8. 110V/220电源转换开关

ACVoItage Selector Switch

技术参数: Technical specifications

Inputs:

Type

Undalanced 1/4' trs Jack

Impedance

44kOhms

Outputs

Type

Undalanced 1/4':trs Jack

Impedance

300 Ohms

Frequency Response

20Hz To 22khz

Maximum Input level

+21dB

Maximum Input Ratio

0.0035\$

S/n Ratio

Fuse

1.0A/115V;0.5A/250V;5mmglass Type

Dimensions

19" × 1.73" × 6.1" (483 × 44 × 155mm)

Weight

4.2ids.(2.1kg)

SPECIFICATIONS AND DESIGN SUBJECT TO CHANGE WITHOT
PRIOR NOTICE FOR IMPROEMENTPURPOSES

专业卡拉OK音频处理中心 Specialized Kara OK audio frequency processing station

5路话筒输入(前3后2)音量单独调节话筒高低音可调,更容易调整,最佳效果
99种人声宣染效果.方便记忆调整2路音频输入可切换
超低音输出增益,频点可调激励功能高,低频点可调节。

5 group microphone inputs (first 3 latter 2) the volume adjusts the microphone high
bass alone adjustable, easier to adjust, the desired effect
99 kind of soundsof people proclaim dye the effect. Facilitates the memory to adjust
2 group audio frequency inputs to be possible to cut the
ultra bass output to increase, the frequency adjustable drive function is high, the low
frequency spot may adjust.

面板介绍 Front panel instrution

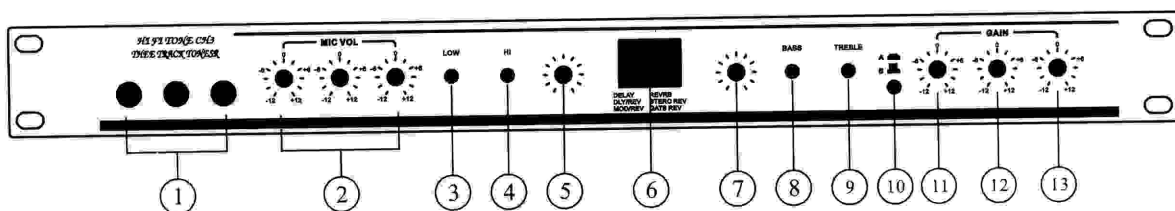

1. 三路话筒输入
Three group microphone inputs
2. 话筒1.2.3.4.5音量调节
Microphone 1.2.3.4.5 volume controls
3. 话筒低音调整
Microphone bass adjustment
4. 话筒高音调整
Microphone treble adjustment
5. 混响时间调整
Mixes the noon time adjustment
6. 数字混响显示
Digital reverberation demonstration
7. 混响深度调整
Reverberation depth adjustment
8. 音频低音调整
Audio frequency bass adjustment
9. 音频高音调整
Audio frequency treble adjustment
10. A/B信号输入通道切换
A/B signal input the channel cu
11. 混响总音量
Reverberation total volume
12. 话筒总音量
Microphone total volume
13. 音乐总音量
Music total volume

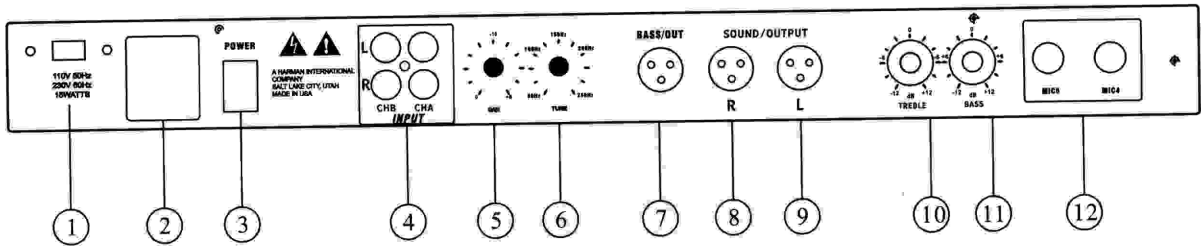

- | | |
|--|--|
| <p>1. 110V/220V转换开关
110V/220V change-over switch</p> <p>2. 电源输入座带保险管
Mains input riggers band protective tube</p> <p>3. 电源开关
Power switch</p> <p>4. 音频A/B输入
Audio frequency A/B input</p> <p>5. 超低音输出增益
Ultra bass output gain</p> <p>6. 超低音扫频
Ultra bass frequency sweep</p> <p>7. 超低音输出
The ultra bass channel outputs</p> | <p>8. 主声道输出 (R)
The main sound track outputs (R)</p> <p>9. 主声道输出 (L)
The main sound track outputs (L)</p> <p>10. 激励高音调节
Drives the sound adjustment</p> <p>11. 激励低音调节
Drives the bass tuning</p> <p>12. MIC4 MIC5输入
MIC4 input</p> |
|--|--|

技术参数: Technical specifications

输入灵敏电阻 Inputs the keen resistance

话筒: ----- 3MV/10-KOHM
Microphone

音乐: ----- 250MV/25-KOHM
Music

频率响应 Frequency response

话筒: ----- 80Hz TO 12KHz. +0/- 3dB
Microphone

音乐: ----- 20Hz TO 20KHz +0/- 3dB
Music

音调控制范围: ----- 11 STEPS + - 21/2TONE
Frequency response

MUSIC: ----- BASS + - 10dB(100Hz)
TREBLE + - 10dB(10KHz)

MICROPHONE: ----- BASS + - 10dB(100Hz)
TREBLE + - 10dB(10KHz)

效果回响范围: ----- MAXO-196MS
Effect echo scope

超低扫频: ----- 50Hz -250Hz
Ultra low scanning

激励: ----- 600Hz+5dB 5KHz+5dB
Maximizer

立体声双31段均衡器

Stereo sound pair of 31 section of balancer

面板介绍 Front panel instruction

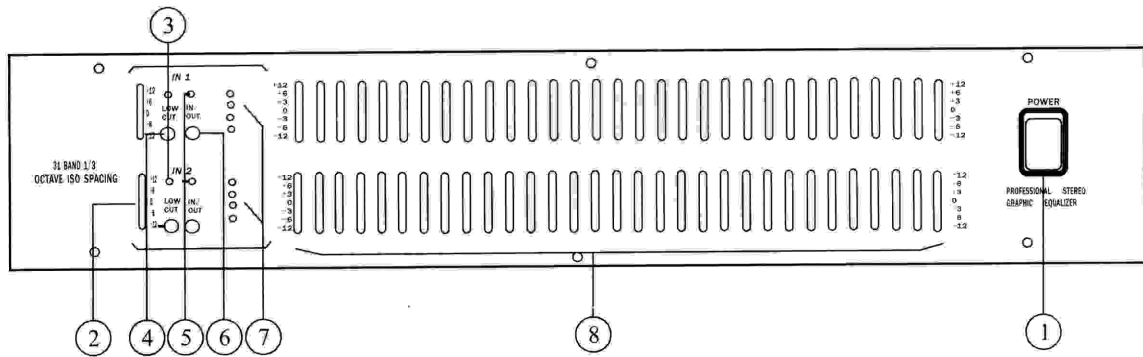

前面板指示图 Front panel indicator card

- | | |
|--|---|
| 1. 电源开关 Power switch | 5. 信号直通指示灯 The signal goes nonstop to the indicating lamp |
| 2. 输入增益 Input gain | 6. 信号直通开关 The signal goes nonstop to the switch |
| 3. 低频剪切指示灯 Low frequency cutting indicating lamp | 7. 电平输出指示灯 Electric equilibrium output indicating lamp |
| 4. 低频剪切开关 Low frequency cutting switch | 8. 均衡部分 Balanced part |

背后板介绍 Rear panel instruction

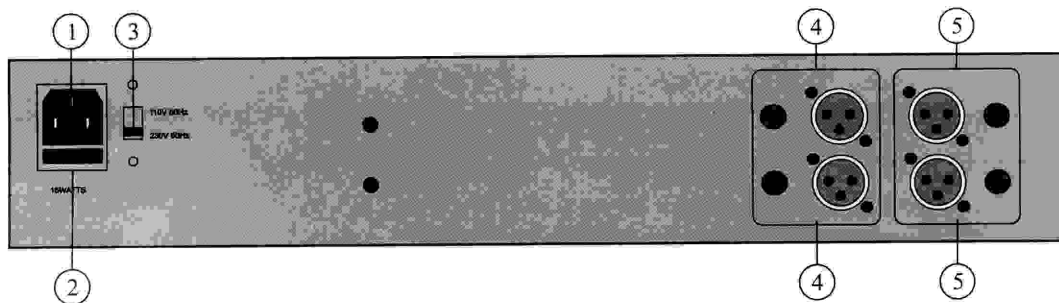

后面板指示图 Rear panel instruction

- | |
|--|
| 1. 交流插座 Exchanges the plug |
| 2. 保险丝仓 Fuse warehouse |
| 3. 交流电压选择开关 Alternating voltage selection switch |
| 4. 输出连接器 Outputs the coupling |
| 5. 输入连接器 Inputs the coupling |

技术参数:technical specifications

频率波段 Frequency wave band	2×31 1/3 octave, iso Spacing
输入 Input	PF Filtered, Servo-Balanced input
输入/输出类型 input/output type	2 Balanced XLR and unbalanced 1/4"
输入阻抗 input Impedance	20Kohms Unbalanced 40Konms Balance
输出阻抗 output Impedance	330 ohms
频率响应 Frequency response	20Hz-20KHz+/-1dB
信噪比 Noise	>95dB
总谐波失真 Total harmonic distortion	0.005%
通道间隔 Channel gap	Better Than 50dB
滤波器控制范围 Filter control area	+/-6dB or +/-12dB Select
最大输出电平 Biggest input level	+21dB
保险丝 Fuse	1.0A/250V, 5mm glass type
尺寸 Size	19×3.46×5.31(482×88×135mm)
重量 Weight	7.01bs(3.5kg)